

73717471757 系列
SERIES

超高速包缝机

SUPER HIGH-SPEED OVERLOCK
SEWING MACHINE

使用说明
Operation Manual
零件图册
Atlas of Parts

致使用者 / To The Operators

我们非常感谢您使用本公司出品之超高速直针锁边缝纫机(拷克车)。请详细阅读此说明书,将使您更了解本机器独特之性能及正确的使用方法,进而提高您缝制的效率与品质。

首先请您注意,请先注入润滑油及确认马达之向为顺时针方向,才可以开动本机器。

Thank you very much for using our Ultra High speed, Straight Needle, Overlock Safety Stitcn Machinc. Before operating this machine, please study this book thoroughly, understand the functions and features of the machine. Then it will help you to increase your sewing efficiency and quality.

ATTENTION: Because this is an ultra high speed machine. Do not run it before filling oil and making sure the correct turection of motor.

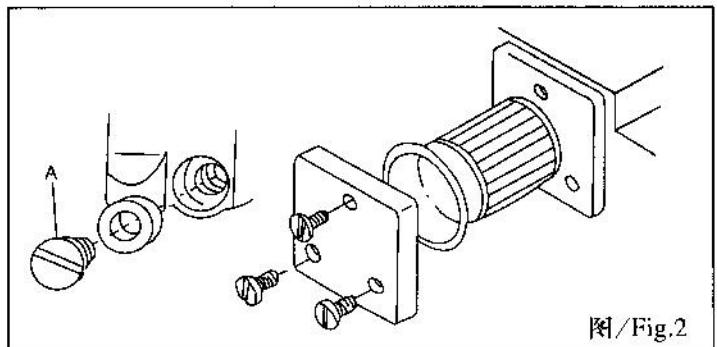
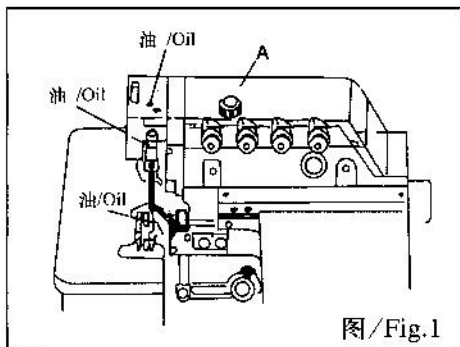

机器安装 / How To Install The Machine

- 1、依本机所附桌板裁制图及零件组合图所列之配件,依序安装也震机座铝板半沉式时,机台针板面与桌板面之距离为100mm,全沉式为5mm。
- 2、马达启动踏板装于左边,拾压脚踏板则装于右边。
- 3、按零件图示装置废料槽及线架。
- 4、注意马达之转向为顺时针方向,皮带之松紧度以用手向内压下缩10mm为宜,皮带轮与缝合转速请参照表1。但常用转速就放为第一档为宜。

1. Install the machine according to the table cut-out diagram, Cushion Rubber and Rest Board as enclosed. In case of semi-submerged, the distance between Needle plate top surface and Table Top is about 100mm, and for fully-submerged is about 5mm.
 2. Setting the pedal of clutch motor to the left side and the pedal of presser foot lift at right ride.
 3. Install the cloth waste chute, thread stand as parts list.
 4. Be sure the motor turning direction is clockwise. And the belt can be pressed inward about 10mm.
- NOTE: The dimensions of motor pulley and sewing speed are shown in Table 1.

新机器之启用规定 / How To Operate The New Machine

新机器在最初启用四个星期内请用低于最高速度20%的速度运转,然后换新润滑即可运转到最高速度。

Please run the new machine in the first four at 20% less speed than maximum. Then replace the new oil and threafter the machine may be operated up to maxim um speed.

润滑油之注入与更换 / Lubrication And Drainage

一、润滑油之注入 图1

- 将螺丝A旋开，以包装箱内所附之超高速润滑油或选用MOBIL#10或SGIP等相当之机油加入，使油量指示杆位于油标上下之间即可，然后再锁紧螺丝A。

二、润滑油之更换 图2

- 将螺丝A放松旋开，使油完全排出后再锁紧。
- 为延长本机器之寿命，请于开始使用四个星期更换新油后约四个月更换一次。
- 本机器特别装有滤油器，约每使用一个月后卸下清洗，必要量更换新品。

三、针之冷却油

- 使用油:硅油

1. Lubrication Fig.1

Remove Screw A and fill in enclosed ultra high speed lubricate oil (or similar to Mobil#10, Esso#32) until the top of Oil Level indicator between two lines of Oil Level Sight Window, Then replace Screw A.

When the machine is operated for the first time is was idle for a long time, please be sure to oil the top of the needle holder, guide, upper looper guide etc . before operating the machine.

2. Drainage Fig.2

Remove Screw A and drain out the oil then cplace Screw A.

For keeping the good lubrication and machine life. please replace the new oil when the new machine has been operating over four weeks, And after that, change oil every four months.

This machine has been fixed with oil filer, Please clean it every month or replace a new one if necessary.

3. Needle Cooling Lubrication-Silicon oil.

穿线方法 / THREADING THE MACHINE

请确实按照图示各种不同缝合形式穿线，错误之穿线将引起断线，跳针或车缝不平坦等现象。

Refer to the sewing type you need for correct threading. Any incorrect threading may cause thread break, uneven stitches or skip stitches etc.

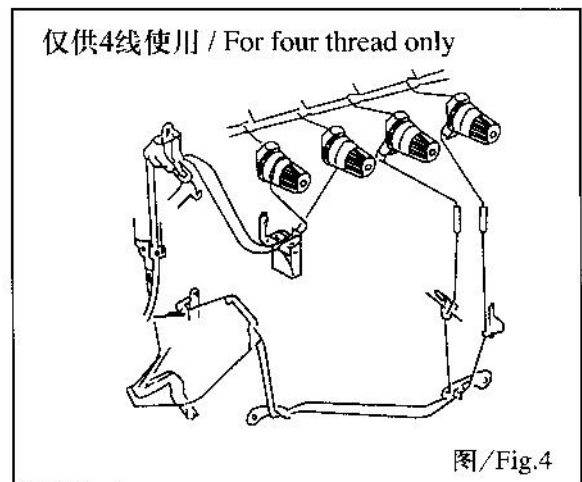
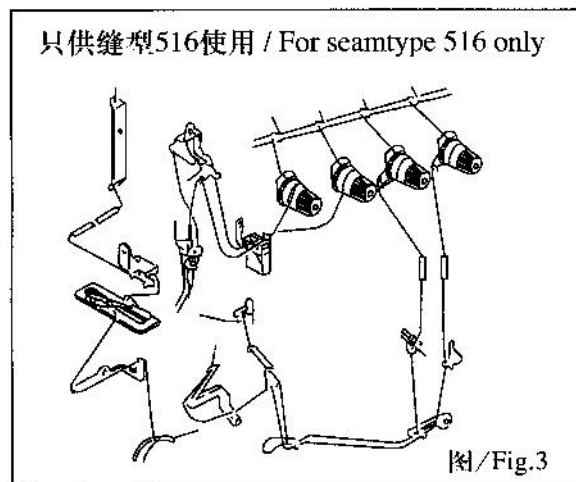

控线调整 / Thread tension

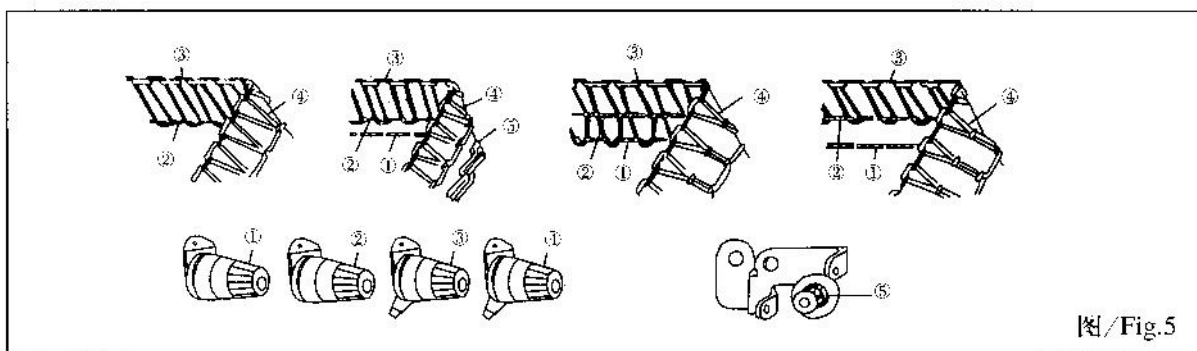

图/ Fig.5

控线强弱必须根据缝合材料种类、厚薄、线、针距及包边宽度等之不同之调整。

The thread tension be adjusted according to sewing fabric, thickness, sewing thread, seam width, stitch length etc. Therefore the pressure of the Tension Nuts or Thread Guides must be adjusted in each individual case.

一、调整钮之控线关系 图5

- 第一调整钮控制双环针线或左边拷克针线。
- 第二调整钮控制包边针线。
- 第三调整钮控制下勾针线。
- 第四调整钮控制双环勾针线。

1. Tension Nuts Adjustment. Fig.5

- The tension Nut ① controls the double chain needle thread or left side overlock needle thread.
- The tension Nut ⑤ controls the double chain looper thread.
- The tension Nut ② controls the overlock needle thread.
- The tension Nut ③ controls the upper looper thread.
- The tension Nut ④ controls the lower looper thread.

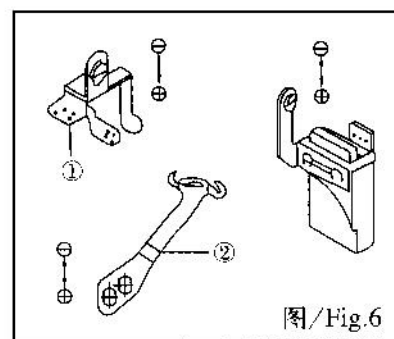

图/ Fig.6

二、针线控线关系 图6

- 在缝合方式504、512、514时，将①②移至最下端，缝合方式503及505时，将①②移至最上端。
- 表示增加针线强度。表示减少针线强度。

2. Needle Thread Control Fig.6

In case of sewing type 504,512,&514, push Thread guide①and ②to lowest point. and up to highest point fo sewing type 503,505.

Note: The (+) direction is for more needle thread tension, and the (-) direction is for less needle thread tension.

三、勾针控线关系 图7

- 在缝合方式为512、504当上勾针移至最左时，将①及②高速整至实线位置，若缝合方式为503、504、514及上勾针移至最左时，将①及②调整至虚线位置。

固定线导板③如下:

A点: 尼龙伸缩线 B点: 拷下摆 C点: 缝合方式512

· 固定线导板4如下:

D点: 尼龙伸缩线 E点: 考下摆 +方向为缝合较多, 反之较少。

3. Loper thread Control Fig.7

For sewing type 512, when Upper Loper is extremely left, push takeup ① and ② at the position as the chain line(-----).

In case of sewing tupe 503, &505, When Upper Loper moves to lowest, set Take up ① and ② at the position as the continuous line (-----).

Adjust thread guide ③ as follow. Point A--for stretchy thread is used.

Point B--for seaming and blindstitch hemming. Point C--for seaming tupe 512.

Adjust Thread guide ④ as follows.

Point D--for stretchy thead is used. Point E--for seaming and blindstitch hemming.

NOTE: The direction is for more thread in sewing seam, and the direction is for less thead in sewing seam.

四、环缝线凸轮控线关系 图8

正确之环线凸轮控线位置是当针提升至最高点时，A点恰好在勾针线导板1之表面，放松凸螺丝2转动凸轮3向反时针方向则勾针线较快。

4. Chain Loper Thread Cam Control Fig.8

When the needle moves to its highest position, the right corner of the Thread Cam ③ matchs with the upper surface of Thread Guide Bracket①.

loosen scrwe ② and adjust the thread cam ③ as clockwise is late for timing of looper thread cam.

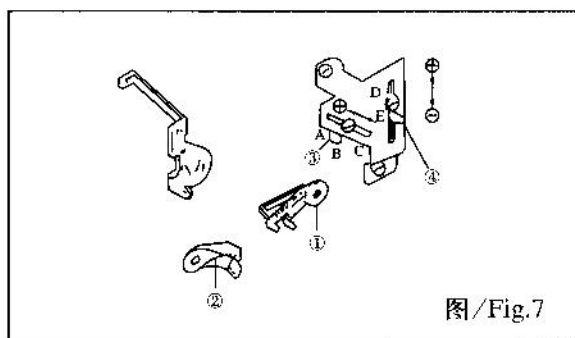

图/ Fig.7

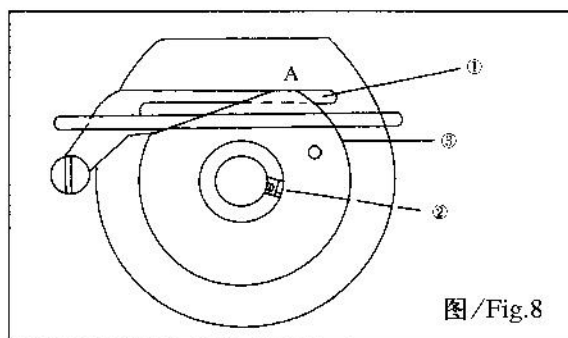

图/ Fig.8

针距调整 / Stitch length adjustment

通常按钮缝合布料，差动比等之不同而调整。

· 持续压下按钮并转动皮带轮使钮卡住，再转动皮带轮至所需之针距后放开此按钮。

The stitch length adjustment is made accoring to the sewing fabric, differential feed ratio etc.

Keep pushing the Push Botton enter deep inside.

Keep pressing the Push Botton and match the desired stitch length which is shown on the pulley with the indicating point of Belt Cover.

最大辩差率 Maxidiff ratio	机 型 Machine type	带轮到度/Pulley scale						
		1	2	3	4	5	6	7
1:2	缝线/Seaming	1	1.5	2	2.5	3	3.5	3.8
1:3	抽褶/Shirring	0.7	1	1.4	1.7	2	2.3	2.5
1:1.3	剪毛边/Sergin	1.6	2.3	3.1	3.9	4.7	5.4	5.9
1:4	特边的/Special	0.6	0.9	1.2	1.5	1.8	2.1	1

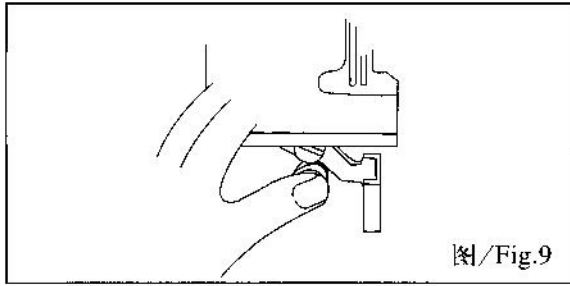

图/ Fig.9

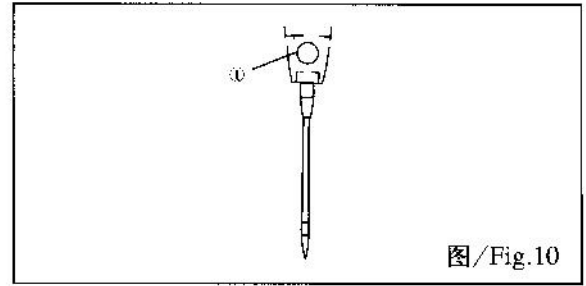

图/ Fig.10

换针 / Needle replacement

- 使用DC+27或同规格之针。 旋开螺丝①并取下针。
- 将新针插至针孔最底端，并使针之长沟面向自己。
- 固定螺丝①。

Please use DCX27 or equivalent needle size.

Loosen Screw① and remove the old needle.

Insert the needle which long groove faces you and push it up deep into the needle hole until it stops and tighten Screw①.

差动比调整(主送料具与分送料具运动程之比) / Differential feed ratio adjustment

若主送料具之运动程大于分送料具运动时，则布料车缝时伸张，反之则收缩。

调整方法为放松螺丝①转动螺丝②顺时针方向时使布料伸张，反之则收缩，高速后再回定螺丝①。

注：当调整杆③之表面固定在刻划2时差动比这1:1。若将其固定在刻划2以上时，可使布料伸张至1:0.7。

The differential feed ratio is the ratio of movements between Main Feed Dog and Differential feed dog, when the movement of main feed dog is bigger than differential feed dog, the fabric be stretched in sewing. Otherwise the fabric be shrunk.

Loosen Nut ① then turn screw ② in clockwise for stretching the fabric, and in reverse direction for shrinking the fabric then tighten Nut ①.

Note: When the surface of adjusting level ③ be set at the scale ② the differential feed ratio is 1:1, and if it be set over the scale its ratio can be adjustable up to 1:0.7.

到度/Scale		1	2	3	4	5
差动进 料比率	1:1.3	-	1:0.7	1:0.9	1:1.1	1:1.3
	1:2	1:0.7	1:1	1:1.4	1:1.7	1:2
Differ- ential Feed ratio	1:3	1:1	1:1.5	1:2	1:2.5	1:3
	1:4	1:1.1	1:1.6	1:2.3	1:2.8	1:3.3

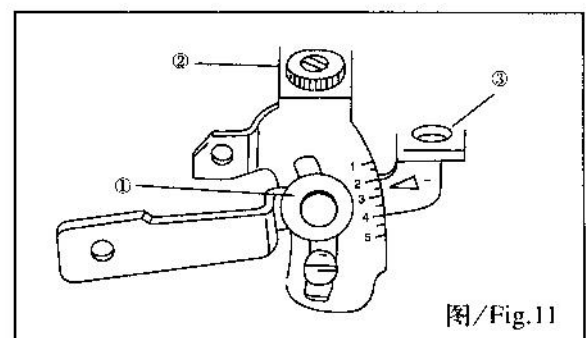

图/ Fig.11

各缝纫元件之相互关系 / Parts relation and timing

一、针于针板之 图12

当针上升至最高时，针尖端(双直时以左针为准)于针板之距离，标准程机器为9.5-9.7mm(但高程机器为10.8-11.0mm)。双针时左右针必须略比左针向前0.3-0.3mm，但右针于板沟前端离1.2mm。

放松针动连杆螺丝①使能以手推动针座滑块，转动皮带轮使针插在孔槽中央，必要时放松螺丝②以调查针座。

转动皮带轮使针到最高点后，轻敲针座滑块至正确针高度后锁紧螺丝①。

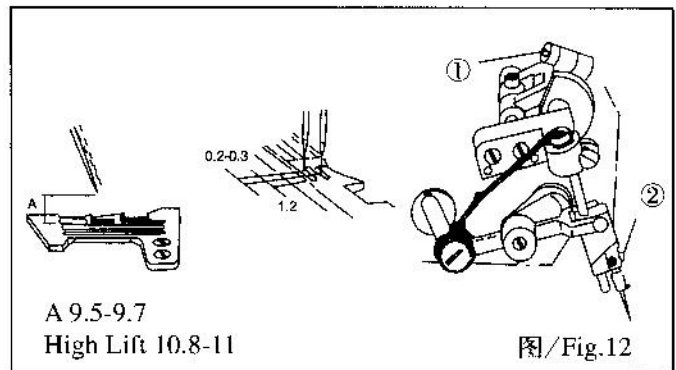

图/ Fig.12

1. Needle and Needle Plate Fig.12

When the Needle moves to the highest position, the distance between needle point (left needle if two needle) and needle plate is 9.5-9.7mm for standard lift machine or 10.8-11.0mm for high lift machine, Each needle must centers in each needle slot of Needle plate. The right needle must ahead about 0.2-0.3mm than left needle. And the distance between the needle point (right needle if two needle) to needle slot of Needle Plate or presser foot is 1.2mm.

Slightly loosen Screw①of Needle Drive Crank. Rotate the pulley to check if needle center in each needle slot of needle plate. or you may loosen screw ②and adjust needle holder.

Rotate the pulley for removing the needle to the highest position, tap the Needle Holder guide until the correct needle height is obtained. Tighten screw①.

二、上勾针与针之关系 图13

当上勾针移至最左时，勾针尖端与针中心线约4.5-5.0mm，双针时其左边针中心线与勾针尖端约距5.5-6.0mm。

2. Upper Looper (Spreader) and Needle Fig.13

When the Upper (spreader) moves to the extremely left, the distance between the point of looper (spreader) and center line of needle is 4.5-5.0, for 1 needle (spreader) to center line of left needle is 5.5-6.0mm for 2 needle machine.

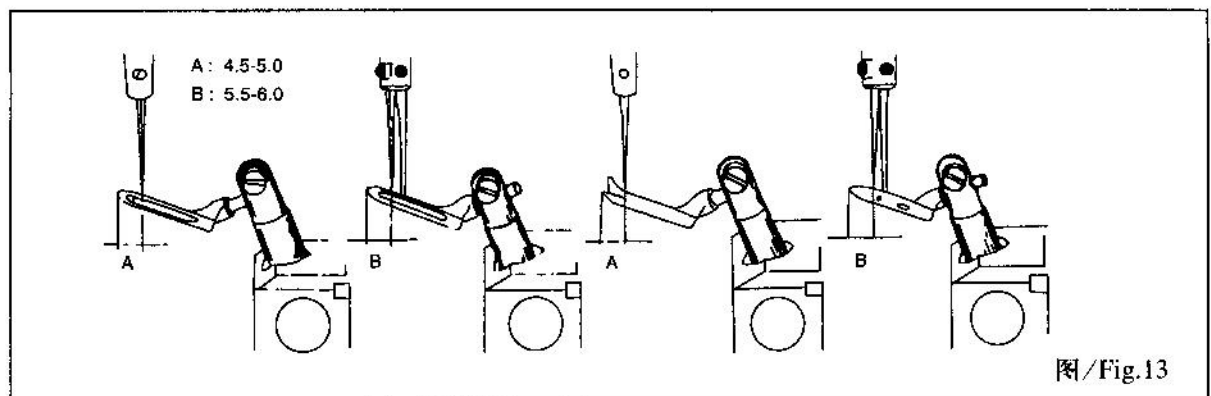

图/ Fig.13

三、下勾针与针之关系 图14、15

当下勾针移至最左时，勾针尖与针中心线(双针时以左针为准)之距离A标准程机构: 3.4-3.2mm高程机器: 3.0-3.2mm。

当下勾针移中心线(双针时以左针为主)时，针与勾针之间隙为0-0.05mm。

四、上勾针与下勾针之关系 图16

当上、下勾针相交会时，两勾针尽可能接近，但不可磨擦相撞，其间隙A点为0.5mm及B点为0.2mm。

当针移到了低位置，针与前导针B之间隙为0.1-0.2mm。

五、针与导针片之关系 图17

当下勾针尖刚好到针(双针时以左针为准)中心线时，针与后导针板A之间隙为0mm当针移到了低位置,针与前导针板B之间隙为0.1-0.2mm。

六、环缝勾针与针之关系 图18

环缝勾针移至最左时勾针尖端与针中心线之距离2.5mm。

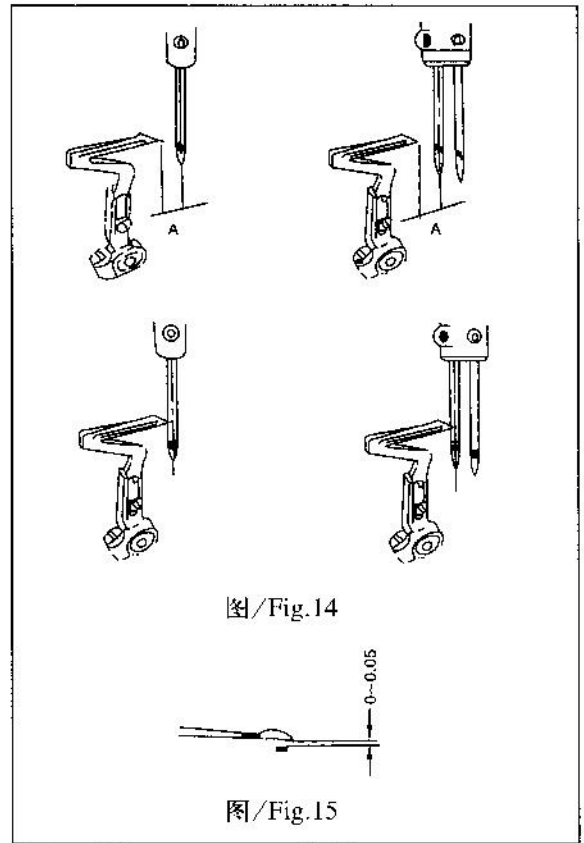

3. Lower Lopper and Needle Fig.14 15

When the lower looper moves to the extremely left, the distance between looper point and center line of needle (left needle if 2 needle) is 3.4-3.2mm for high lift machine. When the lower looper moves to the center line of needle (left needle if 2 needle) the gap between needle and looper is 0-0.05mm.

4. Upper Lopper and Lower Lopper Fig.16

When the Upper and Lower Lopper is crossed.

5. Needle and Needle Guard Fig.17

When the Lower Lopper point is opposite the center line of Needle (left needle if 2 needle), the gap between Needle and rear Needle Guard A is 0mm. When Needle moves to the lowest position, the gap between Needle and front Needle guard B is 0.15-0.2mm.

6. Chain Lopper and Needle Fig.18

The Chain Lopper must be fixed into the lowest position of its holder and when the Chain Lopper moves to the extremely left, the distance between the looper point and center line of needle is 2.5mm.

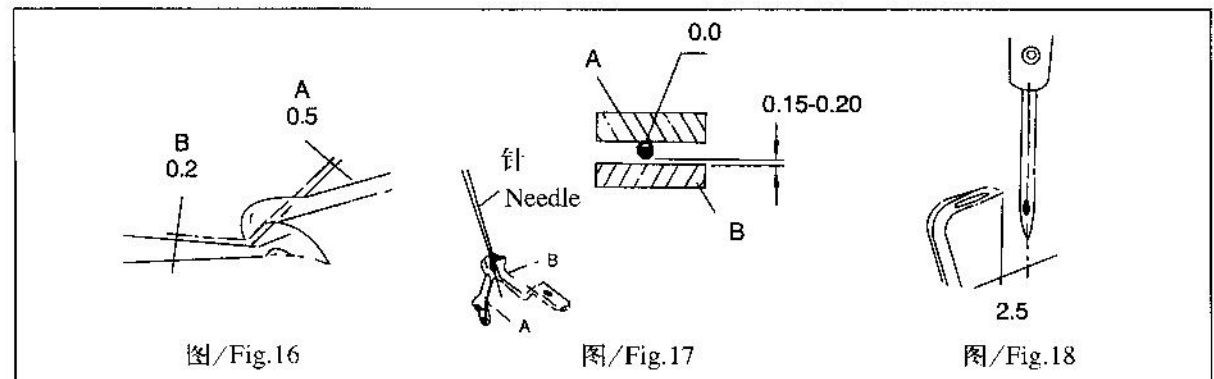

故障排除/Problem settlement:

断针 / Needle break

原因/REASON

- 1、针安装错误
- 2、针尺寸不合
- 3、针已变弯
- 4、针与顶针片之关系错误
- 5、针与勾针之关系错误
- 6、针未入针板沟或压脚沟中央

1. Needle installed wrong
2. Wrong needle size
3. Needle is bended.
4. Wrong relation with Needle Guard.
5. Wrong relation with looper.
6. Needle does not center the needle slot of Needle Plate or Presser Foot.

对策/CORRECT

- 1、重新装针，长沟面向您自己
- 2、选用适合布料及川线之针
- 3、重换新针
- 4、高速顶针片与针之关系
- 5、调整勾针与针之关系
- 6、重新装针板或针，或高速压脚

1. Reset needle correctly.
2. Use properly needle for fabric and thread.
3. Replace new needle.
4. Readjust Needle guard.
5. Readjust looper.
6. Readjust the Needle Plate and Presser Foot.

断线 / Thread break

原因/REASON

- 1、线品质不良
- 2、线粗细不均或比针孔大
- 3、穿线错误
- 4、控线压力太强
- 5、针安装错误
- 6、线架过线错误
- 7、针温度过高: (1)针冷却已无冷却油
(2)针导板装错
- 8、控线片已粗糙
- 9、针与勾针之关系错误
- 10、针、勾针、针板针导板擦起毛头

1. Inferior quality of thread.
2. Thread thicker than Needle hole.
3. Wrong threading.
4. Thread tension is too strong.
5. Needle installed wrong.
6. Thread Stand installed wrong.
7. Over heat of Needle 1.No silicon oil
2 Wrong setting of Needle Guard.
8. Thread Disc or Guide is burred.
9. Wrong relation of Needle and Looper.
10. Needle, Looper needle Plate and guide is burred.

对策/CORRECT

- 1、改用品质好的线
- 2、换适宜之针与线
- 3、重新正确穿线
- 4、高速控线强度
- 5、重新正确装针
- 6、重新装线架使线能通过自如
- 7、(1)加冷却油
(2)调整针导板
- 8、用砂布拉滑后抛光
- 9、调整针与勾针之关系
- 10、磨去毛头或换新品

1. Use good quality thread.
2. Use proper Needle for fabric and thread.
3. Rethreading correctly.
4. Readjust thread tension nut.
5. Reset needle correctly.
6. Reset thread stand for threading smoothly.
7. (1) Fill in Silicone oil.
(2) Readjust Needle Guard.
8. Grind off polish or replace new one.
9. Readjust Needle and Looper.
10. grind off, polish or replace new one.

跳针 / Skip stitches

原因/REASON

- 1、针与勾针之关系错误
 - 2、穿线错误
 - 3、针安装错误
 - 4、控线压力太强或太弱
 - 5、勾针尖端损坏毛头
 - 6、针变弯
 - 7、顶针片安装错误
1. Wrong relation of Needle and Loper.
 2. Wrong threading.
 3. Needle installed wrong.
 4. Inadequate thread tension or tension too strong.
 5. Loper point is damaged.
 6. Needle is bended.
 7. Wrong installed Needle Guard.

对策/CORRECT

- 1、高速针与勾针关系
 - 2、重新正确穿线
 - 3、重新正确装线
 - 4、高速控线强度
 - 5、去除毛头或换新品
 - 6、换新品
 - 7、重新正确安装顶针片
1. Readjust Needle and Loper.
 2. Rethreading correctly.
 3. reset Needle corrcetly.
 4. Readjust Thread Tension Nut.
 5. Replace new one.
 6. Replace new one.
 7. Readjust Needle guard.

松缝合 / Loosen stitches

原因/REASON

- 1、穿线错误
 - 2、线太粗
 - 3、控线圈未压到线
 - 4、针线已无硅油
 - 5、针与勾针装错
1. Wrong threading
 2. Thread is thicker than Needle hole.
 3. Tension Disc do not press thread properly.
 4. Needle thread is not lubricated.
 5. Wrong setting of Needle and Loopers.

对策/CORRECT

- 1、重新确穿线
 - 2、换适当尺寸之针穿线
 - 3、调整控线圈适当压着线
 - 4、添加硅油
 - 5、重新正确安装
1. Rethreading correctly.
 2. Use proper Needle.
 3. Reset Tension Disc properly.
 4. Fill silicon oil.
 5. Readjust needle and loopers.

缝合不均 / Uneven stitches

原因/REASON

- 1、穿线错误
- 2、线架安装错误
- 3、下刀安装错误
- 4、刀剪布未整齐 (1)刀装错 (2)刀钝
- 5、过线孔擦伤
- 6、针尖受损
- 7、送料具高度不适宜
- 8、押具压力太强或太弱

对策/CORRECT

- 1、重新正确穿线
- 2、重新装线架使线能通过自如
- 3、重新安装下刀
- 4、(1)调整刀正确位置 (2)磨掉或换新品
- 5、重新打光
- 6、换新针
- 7、调整正确高度
- 8、调整押具压力强度

1. Wrong threading.
2. Thread stand installed wrong.
3. Lower Knife installed wrong.
4. Knives do not trim neatly.
 - (1) Knives installed wrong.
 - (2) Dull lower knife.
5. Thread Disc or Guide in burred.
6. Needle point is damaged.
7. Inadequate height of feed dogs.
8. Inadequate thread tension.

1. Rethreading correctly.
2. Reset Threadt for threading smoothly.
3. readjust lower knife.
4. Correct as follow:
 - (1) Readjust Knives.
 - (2) Sharpen or replace new knives.
5. Grind off, Polish or replace new one.
6. Replace new Needle.
7. readjust feed dogs.
8. Readjust Thread tension nut.

缝合起皱纹 / Wrinkled stitches

原因/REASON

- 1、控线压力大强
- 2、押具压力太强或太弱
- 3、送料具太突出针板
- 4、刀无法快切
- 5、差动送料未配合
- 6、针太粗
- 7、包边宽度比针板舌狭

1. Thread tension is too strong.
2. Inadequate pressure of presse foot.
3. Inadequate height of feed dogs.
4. Knives do not trim neatly.
5. Differential feed is not matched.
6. Needle is too thick.
7. Seam width is too narrow against the chainoff finger of Needle plate.

对策/CORRECT

- 1、重新高速控线强度
- 2、高速押具压力强度
- 3、调整送料具正高度
- 4、磨利刀片或换新品
- 5、高速适当差动送料
- 6、用适宜布和线之针
- 7、调整包边宽度或换针板舌

1. Readjust thread tension nut.
2. Readjust Presser foot pressure.
3. Readjust feed dogs.
4. Readjust knives or sharpen knives.
5. Readjust differential feed ratio.
6. Use proper Needle for fabric and thread.
7. Rendjust seam width or replace chain off finger.

环缝出线不顺原因 / Thread chain does not come out smoothly

原因/REASON

- 1、押具安装错误
- 2、勾针线凸轮运动时间配合不适当
- 3、环缝勾针安装错误
- 4、穿线错误
- 5、控线强度太大或太弱
- 6、针与勾针之关系错误
- 7、针板或押舌起毛边
- 8、控制片已粗糙

1. Presser foot installed wrong.
2. Inadequate timing of looper thread cam.
3. Double chain looper installed wrong.
4. Wrong threading.
5. Inadequate or too strong thread tension.
6. Wrong relation of Needle and looper.
7. Needle Plate Thread Disc or Presser foot is burred.
8. Thread tension disk is rough.

对策/CORRECT

- 1、重新正确安装
- 2、高速适当轮方位
- 3、重新正确安装
- 4、重新正确穿线
- 5、调整适当控线强度
- 6、调整针与勾针之关系
- 7、用砂布或油石打滑并抛光
- 8、用砂布拉滑并抛

1. Reset presser foot correctly.
2. Readjust Looper thread Cam.
3. Reset Double chain looper correctly.
4. Rethreading correctly.
5. Readjust Thread tension nut.
6. Readjust Needle and looper .
7. Grind off, polish or replace new one.
8. Polish thread tension disk.

一、机壳部分 / Frame assemblies

序号 Ref.No	零件编号 Part No.	名 称 Name	数 量 Amt. Req.		
			3线	4线	5线
1	M1-1A	机壳 machine frame	1	1	1
2	M1-2	针线罩壳护板 needle thread cover plate	1	1	1
3	M1-3A	上节罩 upper oncde cover	1	1	1
4	M1-4A	上节罩垫 upper oncde cover pad	1	1	1
5	M1-5A	车壳上节 lather shell upper knot	1	1	1
6	M1-6	针杆座 needdle plate	1	1	1
7	M1-7	上节垫片 upper washer	1	1	1
8	M1-8	油管 oil tube	1	1	1
9	M1-9	回油胶套 rear oil adhesive case	1	1	1
10	M1-10	油封 oil seal	1	1	1
11	M1-11	后盖板 rear cover	1	1	1
12	M1-12	后盖板油封 rear cover oil seal	1	1	1
13	M1-13	油封 oil seal	1	1	1
14	M1-14	盖板 cover	1	1	1
15	M1-15	油封垫 oil sear washer	1	1	1
16	M1-16	盖板垫 cover washer	1	1	1
17	M1-17	铆钉 rivet	4	4	4
18	M1-18A	机型牌 machine modle plate	1	1	1
19	M1-19	塑料管 model tube	1	1	1
20	M1-20	圆柱销 pin	2	2	2
21	M1-21	滤油网 oil screen	1	1	1
22	M1-22	卡簧 snap ring	1	1	1
23	M1-23	油封I oil seal I	1	1	1
24	M1-24	油封II oil seal II	1	1	1
25	M1-25	开口销 begin pin	4	4	4
26	M1-26	商标牌 trade mark plste	1	1	1
27	M1-28	标牌 mard plate	1	1	1
28	M1-29	油量调节销 oil amount adjusting pin	1	1	1
1	S064	车壳连接螺钉 screw	4	4	4
2	S065	左罩螺钉 screw	3	3	3
3	S054	针杆座螺钉 needle bar asm screw	2	2	2
4	S061	针杆座紧固螺钉 needle lind set screw	1	1	1
5	S009	针杆罩壳护板顶丝 needdle thread cover plate top silk	1	1	1
6	S071	针杆罩壳护板紧固螺钉 needle thread cover plate set screw	1	1	1
7	S041	大盖轴调节螺钉 main cover bearing regulate screw	1	1	1
8	N03	大盖轴调节螺母 main cover bearing regulate nut	1	1	1
9	S032	后盖板螺钉 rear cover plate	11	11	11
10	S036	盖板螺钉 lower cover plate	2	2	2
11	S081	油盘连接螺钉 oil pan join screw	4	4	4
12	W14	油盘连接垫圈 washer	4	4	4
13	W03	油盘连接弹性垫圈 elasticity washer	4	4	4
14	S080	油盘连接内六角螺钉 nexagon socker screw	4	4	4
15	S044	螺钉 screw	1	1	1
16	S065	螺钉 screw	1	1	1

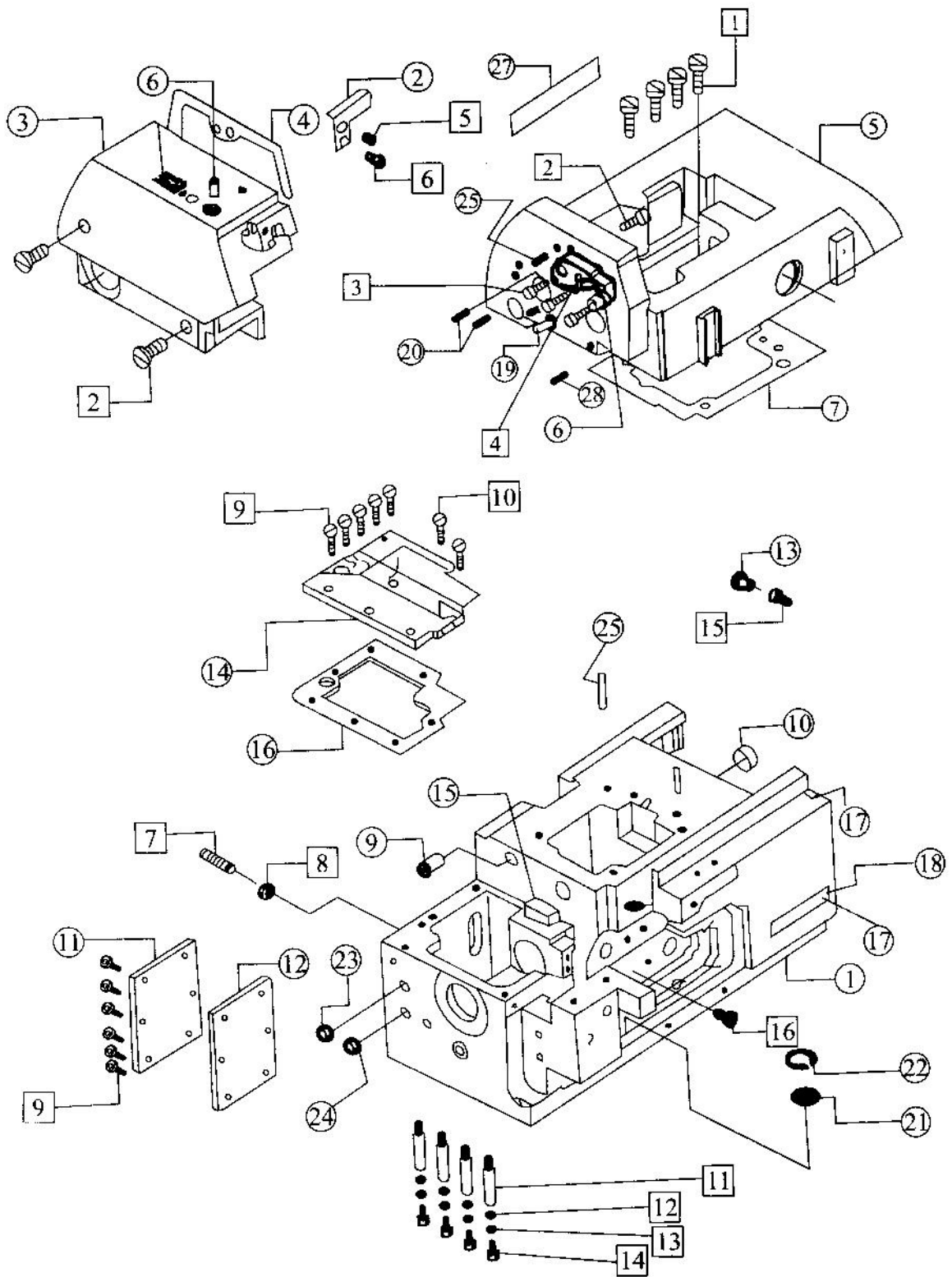

二、缝台部分 / Cloth plate assemblies

序号 Ref.No.	零件编号 Part No.	名称 Name	数量 Amt. Req.		
			3	4	5
1	M2-1	缝台盖组件 cloth plate	1	1	1
	5M2-1	缝台盖组件 cloth plate	0	0	0
2	M2-2	垫圈 washer	1	1	1
3	M2-3	胶套 colloid cose	4	4	4
4	M2-4	胶套 colloid cose	1	1	1
5	M2-5	缝台盖防震螺钉 choth plate spring screw	1	1	1
6	M2-6	弹簧 spring	1	1	1
7	M2-7	缝台盖开启弹簧 cloth plate spring	1	1	1
8	M2-8	缝台盖扳手 cloth plate slider cover	1	1	1
9	M2-9	缝台盖簧 cloth plate cover spring	1	1	1
10	M2-10	缝台下罩壳 cloth plate lower plate	1	1	0
	5M2-10	缝台下罩壳 cloth plate lower plate	0	0	1
11	M2-11	挡油罩 washer	1	1	1
12	M2-12	上弯针密封板 upper looper sealing plate	1	1	1
13	M2-13	上弯针密封板垫 uppr looper sealing plate washer	1	1	1
1	S037	上弯针密封板螺钉 upper looper sealing plate screw	3	3	3
2	S049	大盖扳手螺钉 set screw	1	1	1
3	S010	凸轮上罩螺钉 screw	2	2	2
4	N03	大盖定位螺母 set nut big cover stable screw	2	2	2
5	S083	台螺钉 screw	1	1	1
6	W11	台螺钉垫 screw washer	1	1	1
7	N01	台螺钉螺母 screw nut	1	1	1
8	W08	垫圈 washer	2	2	2
9	S012	大盖簧螺钉 big cover spring vscrew	2	2	2
10	S099	大盖连接螺钉 big cover join screw	3	3	3
11	W07	大盖连接螺钉垫圈 big cover join screw washer	3	3	3

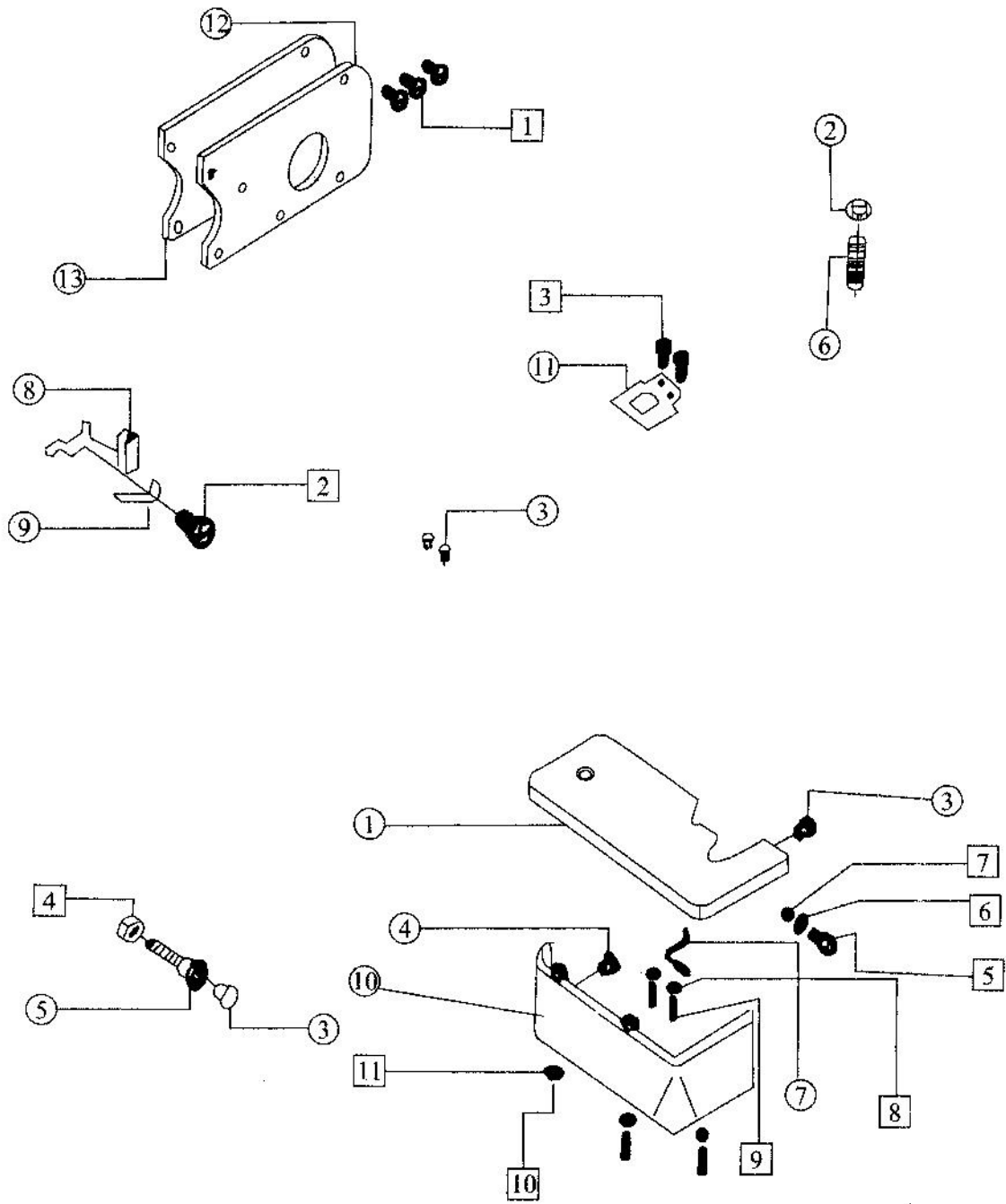

三、罩壳部分 / Cover assemblies

序号 Ref.No	零件编号 Part No.	名称 Name	数量 Amt. Req.		
			3	4	5
1	M3-12	上盖 upper cover	1	1	1
2	M3-2	上盖垫 upper cover washer	1	1	1
3	M3-3	过线架 thread guide supporter	1	1	1
4	M3-4A	皮带轮罩 belt cover	1	1	1
5	M3-5	机线罩壳簧 thread cover spring	1	1	1
6	M3-6	缝料挡板 cloth guide plate	1	1	1
7	M3-7	挡油板II oil guide II	1	1	1
8	M3-8	前罩架销 pin	1	1	1
9	M3-9	前罩簧片 front spring	1	1	1
10	M3-10	前罩 front cover	1	1	1
11	M3-11	前罩挡板 front cover guard	1	1	0
	5M3-11	前罩挡板 front cover guard	0	0	1
12	M3-12	前罩架 front cover hinge	1	1	1
13	M3-13	前罩销 hinge pin	1	1	1
14	M3-14	前罩架弹簧 front cover hinge spring	1	1	1
15	M3-15	前罩架垫 front cover hinge washer	1	1	1
16	M3-16A	商标牌 trade mark plate	1	1	1
17	M3-17	进油指示 oil flow window	2	2	2
18	M3-18	前罩挡板簧 front cover snap guard	1	1	1
19	M3-19	挡油板I oil guard I	1	1	1
20	M3-20	油标垫 oil idverl gauge washer	1	1	1
21	M3-21	上罩销 pin	1	1	1
22	M3-22A	油标盖 oil cover gauge cover	1	1	1
23	M3-23A	有机玻璃罩 oil sight	1	1	1
24	M3-24	垫圈 washer	1	1	1
25	M3-25	商标牌 trade mark plate	1	1	1
26	M3-26A	上罩 upper cover	1	1	1
1	S098	上盖螺钉 upper cover screw	4	4	4
2	S091	过线架螺钉 thread guard screw	2	2	2
3	S017	上罩簧片螺钉 upper cover spring screw	3	3	3
4	W17	垫圈 wather	2	2	2
5	S032	缝料挡板螺钉 cloth guide plate screw	5	5	5
6	S020	挡油板螺I oil guard screw I	2	2	2
7	S090	挡板螺钉 snap plate	4	4	4
8	S082	铰链销固定螺钉 screw	3	3	3
9	S027	铰链板卡簧螺钉 front cover plate blkek spring screw	2	2	2
10	S024	前罩架螺钉 front cover hinge screw	3	3	3
11	W11	前罩架垫 front cover hinge washer	3	3	3
12	E02	卡簧 snap uing	1	1	1

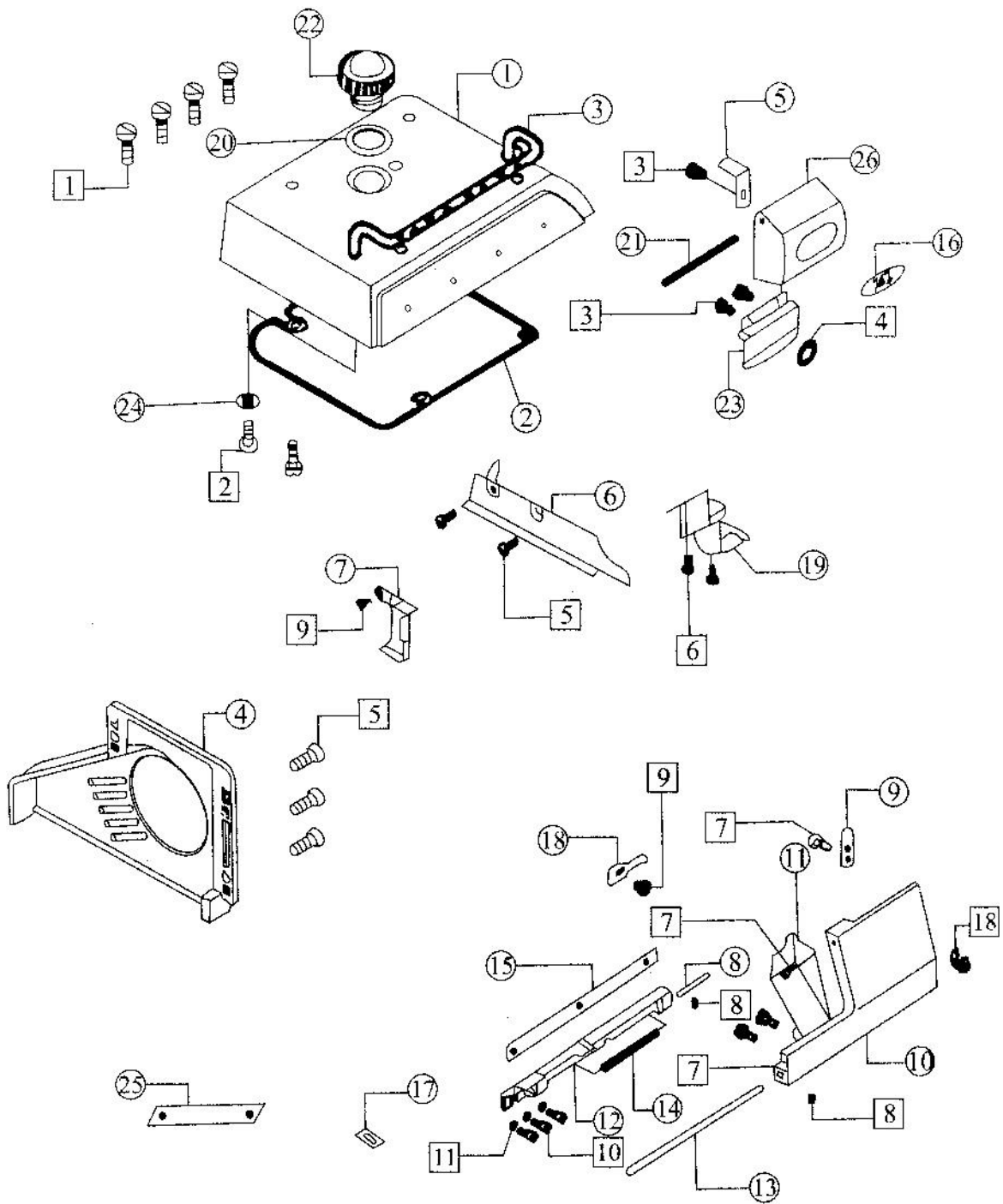

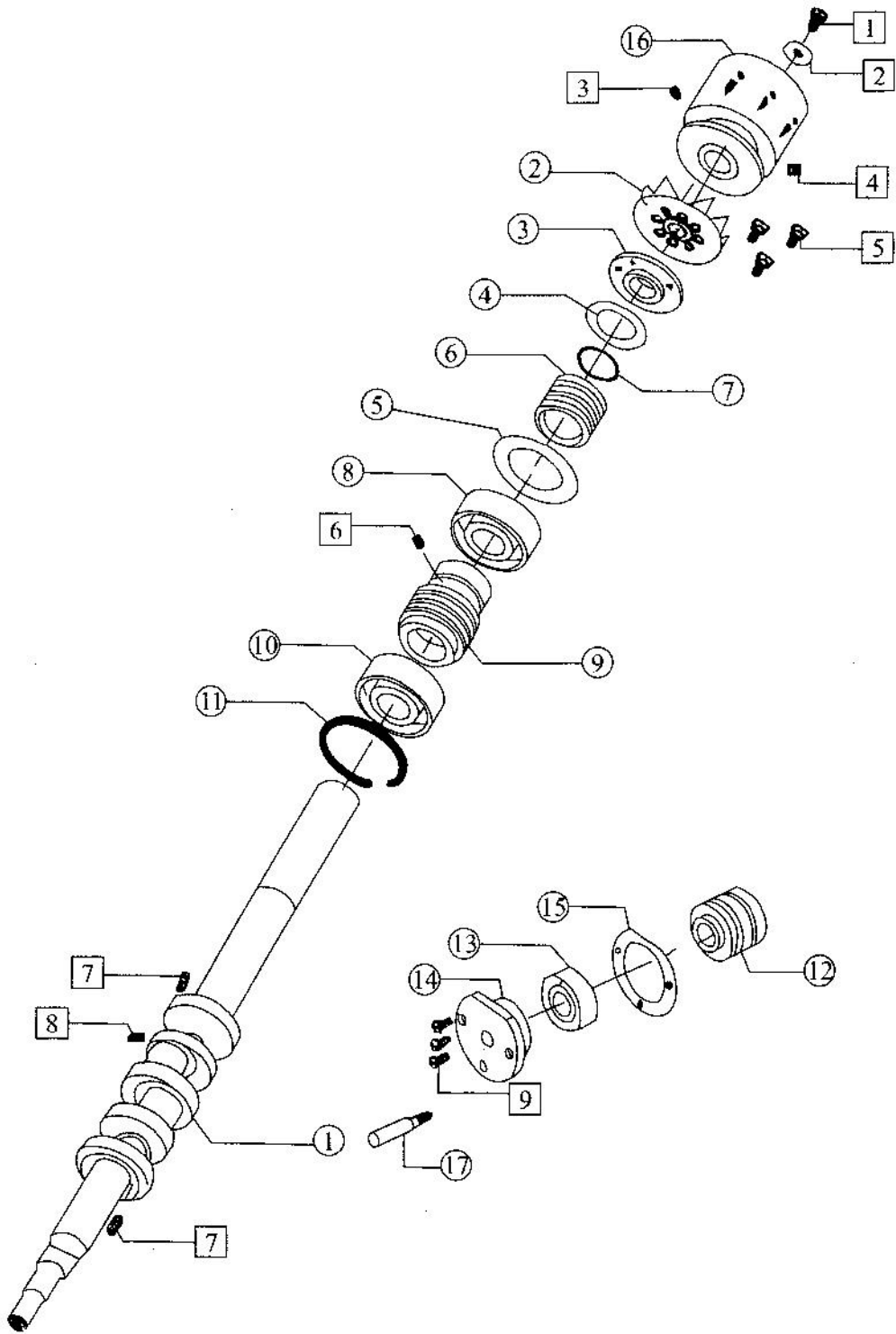

五、针杆部分 / Needle bar assemblies

序号 Ref.No	零件编号 Part No.	名称 Name	数量 Amt. Req.			
			3	4	5	
1	M5-1	针杆曲柄轴	needle bar driving frame rock shaft	1	1	1
2	M5-2	针杆曲柄销	eccentric shaft	1	1	1
3	M5-3	针杆轴后套筒	needle bar shaft bushing back	1	1	1
4	M5-4	挡圈	snap ring	1	1	1
5	M5-5	针杆传动曲柄	throat driving crank	1	1	1
6	M5-6	油线	oi wick	1	1	1
7	M5-7	滚针轴承	needle bearing	1	1	1
8	M5-8	垫圈	washer ring	1	1	1
9	M5-9	针夹导线销	throat clip guide pin	1	1	1
10	M5-10	油线	oil wick	1	1	1
11	M5-11	针杆摆轴	throat bar rock crank	1	1	1
12	M5-12	行针轴左套筒	needle driving shaft bearing	1	1	1
13	M5-13	密封圈	seal ring	2	2	2
14	M5-14	行针轴右套筒	needle bar rear driving copper bearing	1	1	1
15	M5-15	挡圈	snap ring	2	2	2
16	M5-16	针杆摆轴平衡块	balance block	1	1	1
17	M5-17	针杆摆轴曲柄	needle bar frame rock shaft crank	0	1	0
	5M5-17	针杆摆轴曲柄	throat bar shaft crank	1	0	1
18	M5-18	针杆传动连杆	needle bar connecting rod	1	1	1
19	M5-19	针杆传动连杆销	connecting link pin	1	1	1
20	M5-20	垫圈	washer	1	1	1
21	M5-21	针平夹导套	throat clip guide bushing	1	1	1
22	M5-22	针夹导杆体	needle bar	1	1	1
23	M5-23	毛毡	oil felt	1	1	1
24	M5-24	油线	oil wick	1	1	1
25	M5-25	塑料管	plasties tube	1	1	1
26	M5-26	油线	oil wick	2	2	2
27	4M5-27	针占	needle clamp	0	1	0
	3M5-27	针占	needle clamp	1	0	0
	5M5-27	针占	needle clamp	0	0	0
28	M5-58	机针	needle	0	0	1
29	M5-59	油封	oil seal	1	2	2
1	S057	挡圈螺钉	snap ring screw	4	4	4
2	S102	针杆摆轴曲柄螺钉	hexagon socket screw	1	1	1
3	S055	针杆摆轴平衡块螺钉	balance block position screw	2	2	2
4	S043	行针传动连杆顶丝	frame rock shaft set screw	3	3	3
5	S074	行针传动连杆螺钉	shaft position screw	2	2	2
6	S053	针杆曲柄紧固螺钉	screw	1	1	1
7	S001	油线堵油螺钉	screw	1	1	1
8	S006	垫圈螺钉	screw	1	1	1
9	S012	垫圈螺钉	screw	1	1	1
10	S009	顶圈螺钉	screw	5	5	5
11	E01	卡簧	snap ring	1	1	1

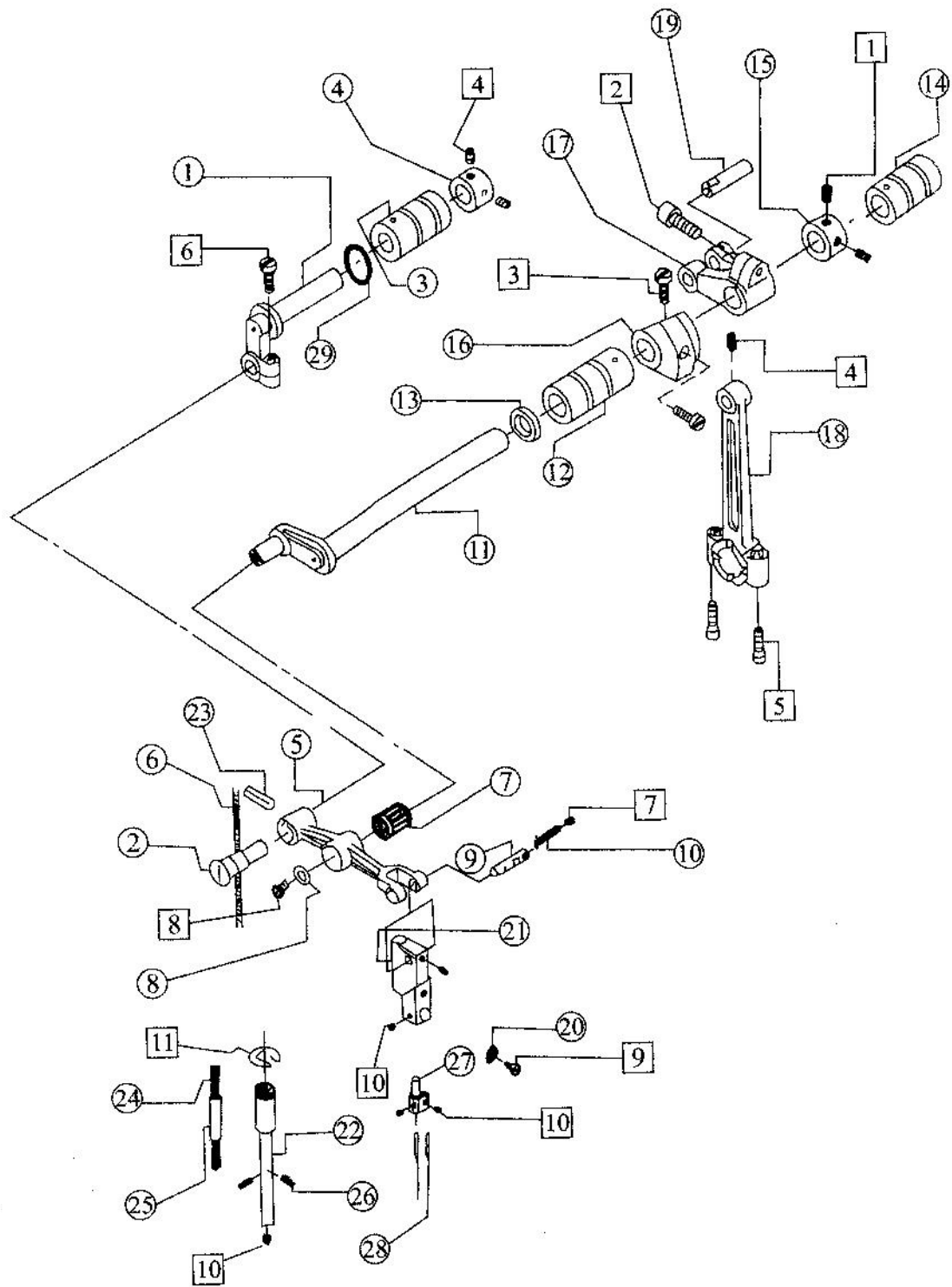

六、过线部分 / Thread guide assemblies

序号 Ref.No	零件编号 Part No.	名称 Name	数量 Amt. Req.			
			3	4	5	
1	M6-1	弯针调压簧	thread tension spring	1	2	2
2	M6-2	夹线螺钉	thread tension screw	3	4	4
3	M6-3A	调压螺母	thread tension nut	3	4	4
4	M6-4	调压止动套	thread tension spring	3	4	4
5	M6-5A	调压止动盖	thread tension spring retainer house	3	4	4
6	M6-6	线片	thread tension disc	6	8	8
7	M6-7	夹线片垫	thread tension disc washer	3	4	4
8	M6-8A	过线板	thread guide	2	2	2
9	M6-9	挑线板	upper thread take-up	1	1	0
	5M6-9	挑线板	upper thread take-up	0	0	1
10	M6-10	硅油盒	oil box	1	1	1
11	M6-11	油毡垫架	oil felt	1	1	1
12	M6-12	过线架	thread guide	1	1	1
13	M6-13	硅油盒胶垫	oil box washer	1	1	1
14	M6-14	油毡垫	oil felt	1	1	1
15	M6-15	拦线板	tension spring	1	1	1
16	M6-16	拦线板去架	thread controller disc holder	1	1	1
17	M6-17	弹簧	spring	1	1	1
18	M6-18	拦线板导向套	thread controller disc guide bushing	1	1	1
19	M6-19	针板座键	throat plate positionign rod	2	2	2
20	M6-20	针板座	throat plate barcket	1	1	1
21	M6-21	过线架	thread mark guide	1	1	0
	5M6-21	过线架	thread mark guide	0	0	1
22	M6-22	护针挡	teat needle guard	1	1	1
23	M6-23	调压簧	thread tension spring	2	2	2
24	4M6-24	前护针挡	front needle guard	0	1	0
	3M6-24	前护针挡	front needle guard	1	0	0
	5M6-24	前护针挡	front needle guard	0	0	1
25	4M6-25	针板	throat plate	0	1	0
	3M6-25	针板	throat plate	1	0	0
	5M6-25	针板	throat plate	0	0	1
26	M6-26A	过线板	thread guide	1	2	1
27	5M6-27	过线	thread guide	0	0	1
28	5M6-28	护针I	needle guard I	0	0	1
29	5M6-29	护针挡II	needle guide II	0	0	1
30	M6-30	护针挡座	needle guard barcket	1	1	0
	5M6-30	护针挡座	needle guard barcket	0	0	1
31	M6-31	挡板	snap plate	1	1	1
32	M6-32	挡板垫	snap plate washer	1	1	1
1	S099	螺钉	screw	1	1	1
2	S035	针板螺钉	throat plate screw	2	2	2
3	S016	前护针板螺钉	fornt needle snap screw	1	1	1
4	S061	针板座螺	throat plat barcket screw	2	2	2
5	S015	过线架螺钉	thread guide holder screw	2	2	2

序号 Ref.No	零件编号 Part No.	名称 Name	数量 Amt. Req.			
			3	4	5	
6	S033	硅油盒固定螺钉	oil box set screw	1	1	1
7	S072	硅油盒胶垫固定螺钉	oil box washer set screw	1	1	1
8	S005	后护针挡螺钉	rear needle guard screw	2	2	2
9	S023	护针挡螺钉	needle guard screw	1	1	1
10	W07	护针挡垫圈	needle tuard washer	1	1	1
11	S017	挑线螺钉	thread take up screw	2	2	2
12	S103	挡板螺钉I	snap plate screw I	2	2	2
13	S019	挡板螺钉II	snap plate screw II	1	1	1
14	S104	挡板定位螺钉	snap plate set screw	1	1	1
15	S045	护针挡座螺钉	screw	2	2	2

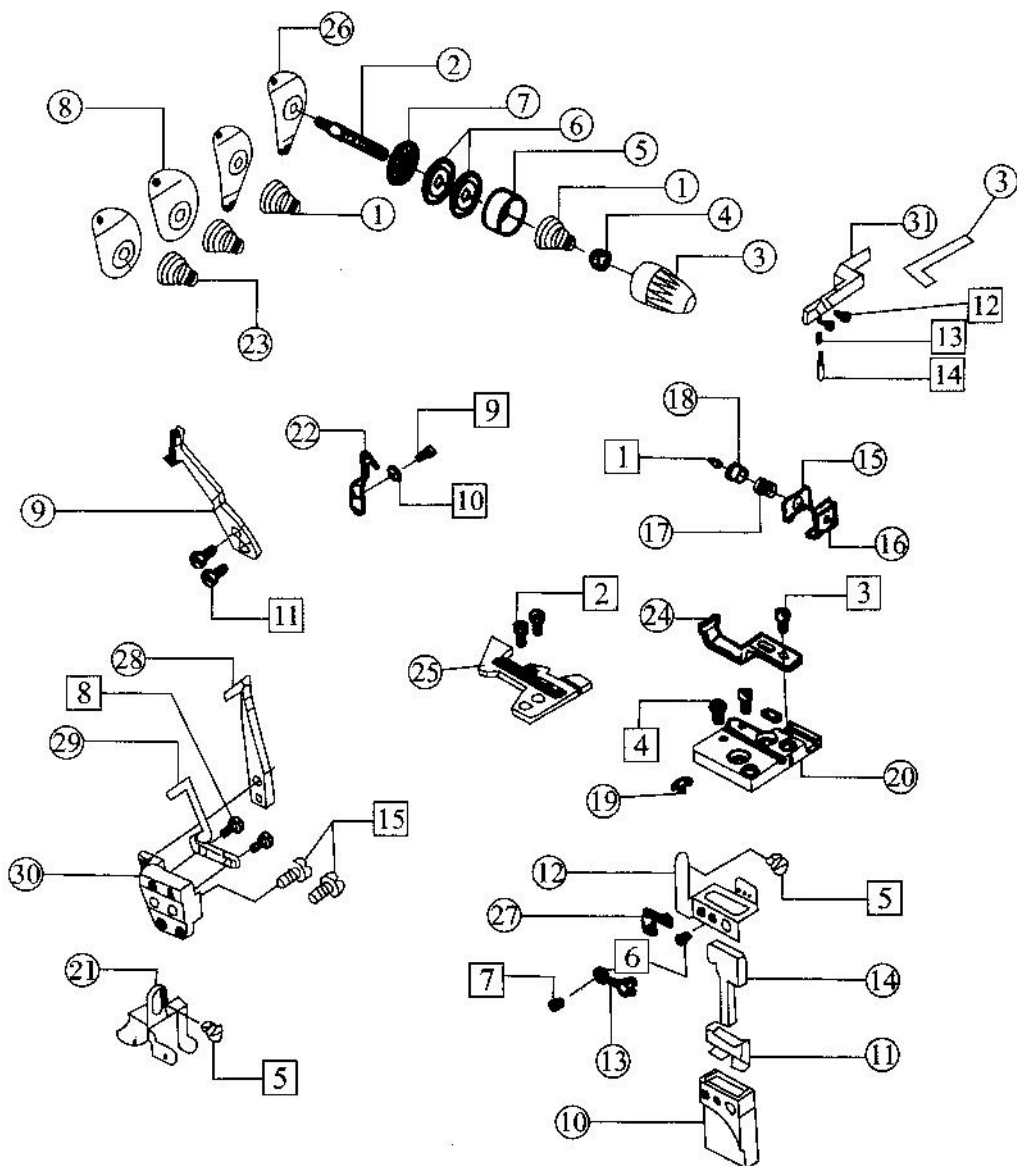

七、上弯针部分 / Upper looper assemblies

序号 Ref.No	零件编号 Part No.	名称 Name	数量 Amt. Req.		
			3	4	5
1	M7-1	弯针连杆 looper link	2	2	2
2	M7-2	弯针连杆摆架 looper link holder	2	2	2
3	M7-3	厚垫圈 thickness washer	0	1	0
	5M7-3	厚垫圈 thickness washer	1	0	1
4	M7-4	上弯针轴 upper looper shaft	1	1	1
5	M7-5	大垫圈 big washer	1	1	1
6	M7-6	上弯针轴后套筒 upper looper shaft rear bashing	1	1	1
7	M7-7	上弯针轴前套筒 upper looper shaft foot bushing	1	1	1
8	M7-8	上弯针轴油封 upper looper shaft oil seal	1	1	1
9	M7-9	上弯针轴曲柄 upper looper shaft crant	1	1	1
10	M7-10	上弯针摇杆 upper looper shaft bar	1	1	1
11	M7-11	摇杆销 connecting rod shaft pin	1	1	1
12	M7-12	摇杆卡片 washer	1	1	1
13	M7-13	油线 oil wick	1	1	1
14	M7-14	上弯针轴导块 upper looper slide bar slidel block	1	1	1
15	M7-15	油毡 oil felt	2	2	2
16	M7-16	油毡 oil felt	1	1	1
17	M7-17	油线 oil wick	2	2	2
18	M7-18	滤油板 acreen oil plate	1	1	1
19	M7-19	压板 felt plate	1	1	1
20	M7-20	导架座挡板 thread hider snap plate	1	1	1
21	M7-21	上弯针轴导架座 upper looper shaft slide bar bracket	1	1	1
22	M7-22	油封 oil seal	2	2	2
23	M7-23	油管 oil tube	1	1	1
24	M7-24	油管 oil tube	1	1	1
25	M7-25	调线刻度板 thread amount regulating plate	1	1	1
26	M7-26	上弯针过线 upper looper thread guide	1	1	1
27	M7-27	上弯针轴过线板 upper looper shaft thread plate	1	1	1
28	M7-28	轴承挡板 shaft bearing guaid	2	2	2
29	M7-29	滚针端面轴承 lower looper holder copper	1	1	1
30	M7-30	弯针 looper	1	1	1
31	M7-31	上弯针摆动曲柄 upper looper crank bearing	0	1	0
	5M7-31	上弯针摆动曲柄 upper looper crank bearing	1	0	1
32	M7-32	穿线管 threading rube	2	2	2
33	M7-33	两孔过线板 two for thread guide	1	1	1
1	S074	连杆螺钉 shaft screw	8	8	8
2	S0384	弯针连杆止动螺钉 screw	2	2	2
3	S058	上弯针轴曲柄螺钉 upper looper shaft crank screw	1	1	1
4	W12	上弯针轴曲柄垫圈 upper looper shaft washer	1	1	1
5	S009	上弯针轴曲柄丝 link pin set screw	1	1	1
6	S101	摆动曲柄螺钉 ncxagon socket screw	1	1	1
7	S036	上弯针轴螺钉 upper looper shaft screw	1	1	1
8	W04	弹簧垫圈 wather	1	1	1
9	S032	上弯针轴过线架螺钉 upper looper shaft thread guide screw	2	2	2

序号 Ref.No	零件编号 Part No.	名称 Name	数量 Amt. Req.			
			3	4	5	
10	S027	调线刻度板螺钉	thread amount regulating plate	2	2	2
11	S037	调线刻度板螺钉	screw	1	1	1
12	S014	弯钉过线螺钉	looper shaft thread guide screw	2	2	2
13	W08	弯钉过线垫圈	looper shaft thread guide washer	2	2	2
14	S097	上弯钉轴导板螺钉	upper looper shaft thread plate screw	1	1	1
15	S062	上弯钉轴导板螺钉	upper looper shaft thread plate screw	1	1	1
16	S012	导架座挡板螺钉	thread holder snap plate screw	1	1	1
17	S095	导线座挡板螺钉	thread holder snap plate screw	1	1	1
18	S015	上弯钉紧固螺钉	upper looper set screw	1	1	1

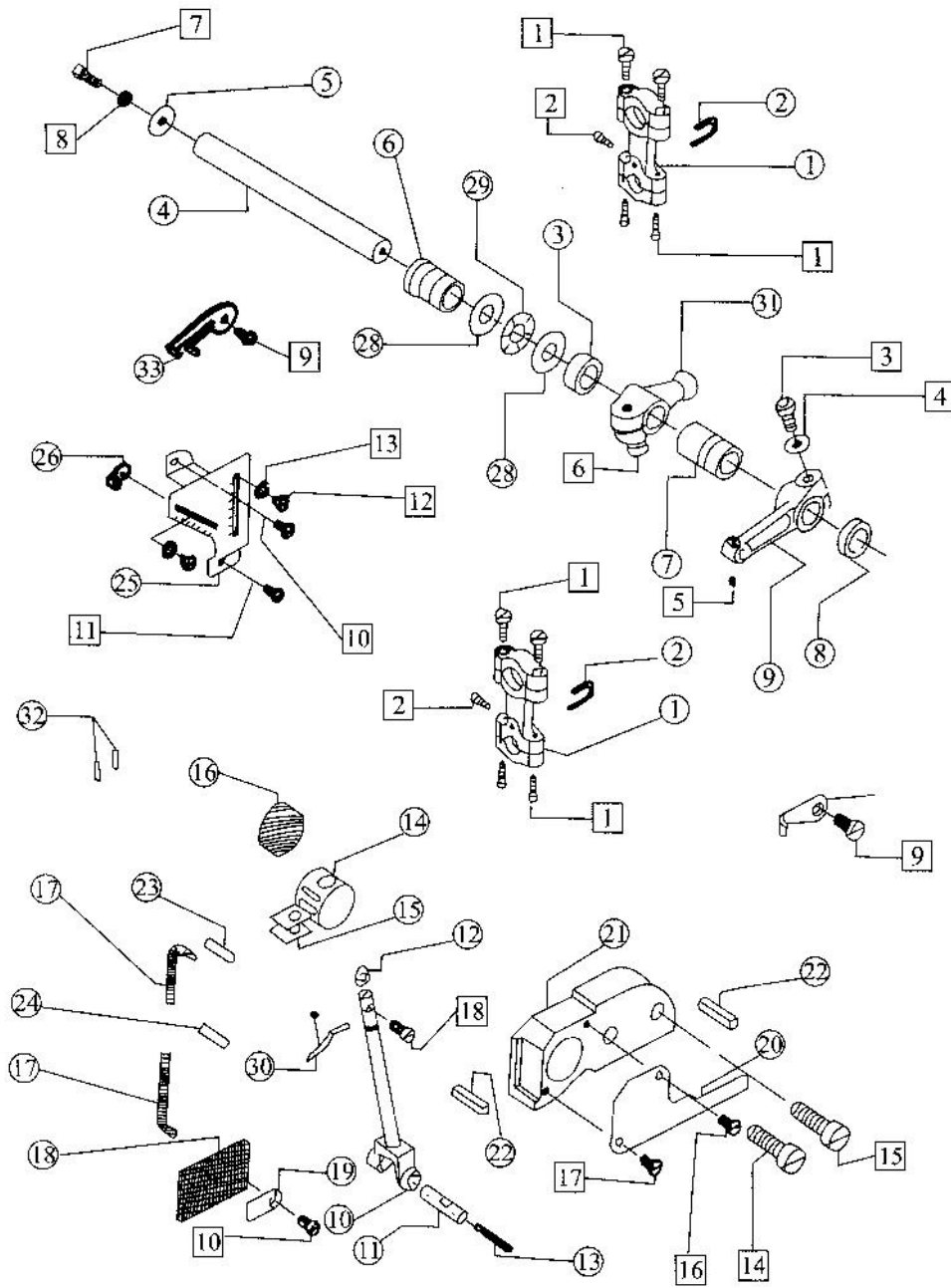

八、下弯针部分 / Lower looper assemblies

序号 Ref.No	零件编号 Part No.	名称 Name	数量 Amt. Req.		
			3	4	5
1	M8-1	厚垫圈 lower looper shaft copper bushing	1	1	0
	5M8-1	厚垫圈 washer	0	0	1
2	M8-2	下弯针轴垫圈 lower looper shaft washer	1	1	1
3	M8-3	油封 oil seal	1	1	2
4	M8-4	下弯针前套筒 lower looper front bushing	1	1	1
5	M8-5	下弯针后套筒 lower looper rear bushing	1	1	1
6	M8-6	下弯针架 lower looper holder	1	1	1
7	M8-7	下弯针曲柄垫片 lower looper crank washer	2	2	5
8	M8-8	下弯针 lower looper	1	1	0
9	M8-9	铜垫圈 copper washer	1	1	1
10	M8-10	过线 thread guide	1	1	1
11	M8-11	下弯针过线 lower looper thread guide	1	1	1
12	M8-12	下弯针三孔过线 lower looper 3-thread guide	1	1	1
13	M8-13	下弯针轴 lower looper shaft	1	1	0
	5M8-13	下弯针轴 lower looper shaft	0	0	1
14	M8-14	下弯针摆动曲柄 lower looper crank	1	1	0
	5M8-14	下弯针摆动曲柄 lower looper crank	0	0	1
1	S036	下弯针轴螺钉 lower looper shaft screw	1	1	1
2	W04	弹簧垫圈 elastic washer	1	1	1
3	S101	摆动曲柄螺钉 crank screw	1	1	1
4	S060	下弯针架钉 lower looper holder screw	1	1	1
5	W12	下弯针架垫圈 lower looper holder washer	1	1	1
6	W07	下弯针架垫圈 lower looper holder washer	1	1	1
7	S022	下弯针螺钉 lower looper screw	1	1	1
8	S032	下弯针过线螺钉 lower looper thread guide screw	1	1	1
9	S067	曲柄螺钉 crank screw	0	0	2
10	S015	曲柄螺钉 crank screw	0	0	2

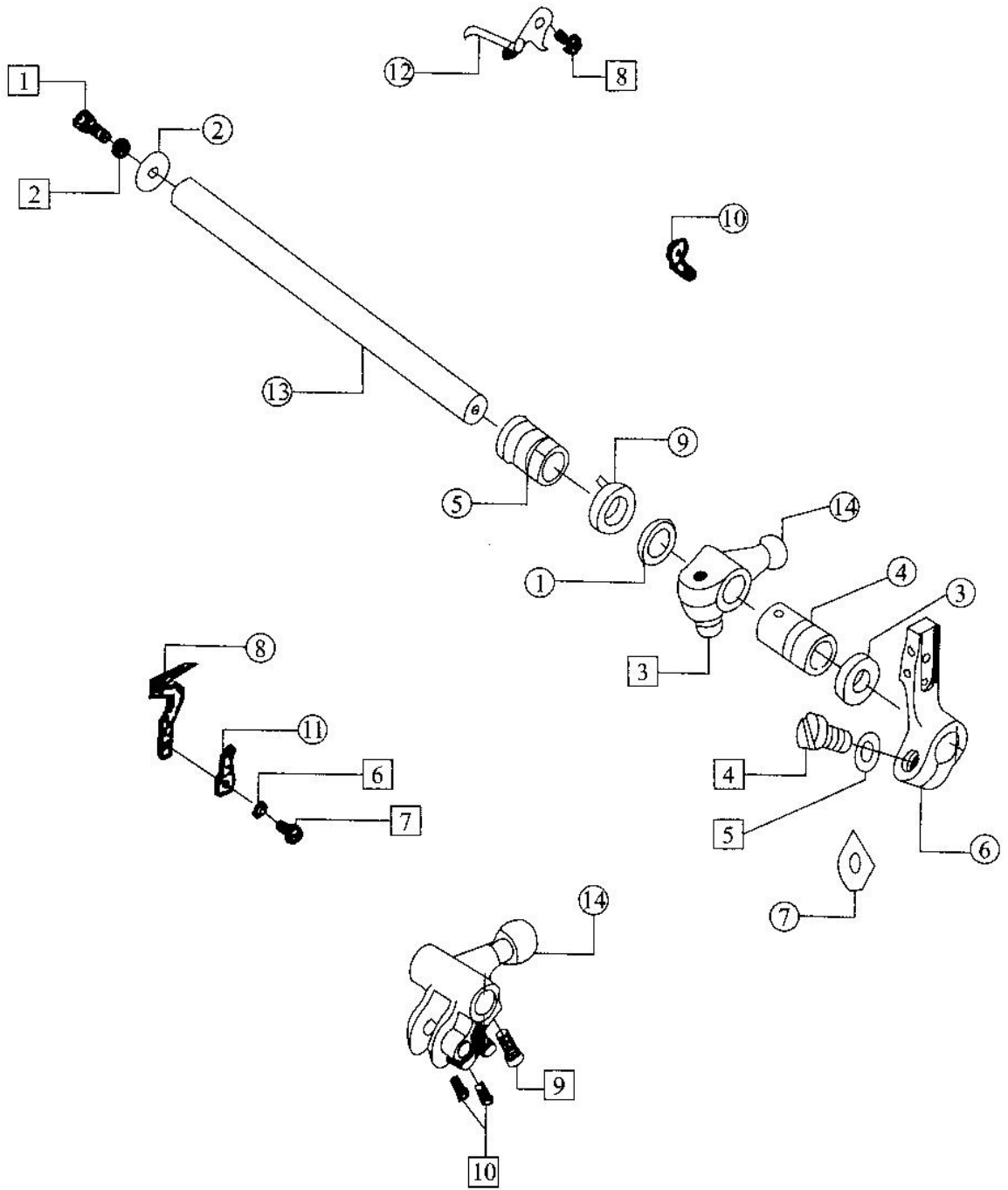

九、前弯针部分 / Front lower looper assemblies

序号 Ref.No	零件编号 Part No.	名 称 Name	数 量 Amt. Req.		
			3	4	5
1	5M9-1	前弯针架 front looper shaft holder	0	0	1
2	5M9-2	前弯针 front looper	0	0	1
3	5M9-3	前弯针调节垫片 front looper shaft regulding washer	0	0	1
4	5M9-4	前弯针曲柄 frong looper crank	0	0	1
5	5M9-5	调节板 regulafting plate	0	0	1
6	5M9-6	调节板销 tegulating palte pin	0	0	2
7	5M9-7	油线 oil thread	0	0	2
8	5M9-8	前弯针轴前套筒 front looper shaft front bushing	0	0	1
9	5M9-9	前弯针轴后套筒 front looper shaft rear bushing	0	0	1
10	5M9-10	前弯针轴 frong looper shaft	0	0	1
11	5M9-11	驱动座 driving lever	0	0	1
12	5M9-12	驱动曲柄 driving crank	0	0	1
13	5M9-13	前弯针滑块 front looper slide block	0	0	1
1	S005	前弯针调节垫螺钉 front looper thread ruide screw	0	0	1
2	S016	前弯针固定螺钉 front looper guide set screw	0	0	1
3	S060	前弯针架螺钉 front looper holder set screw	0	0	1
4	W12	前弯针架螺钉垫 front looper holder screw washer	0	0	2
5	S028	前弯针曲柄螺钉 front looper crank screw	0	0	2
6	S101	前弯针曲柄紧固螺钉 front looper crank holder set screw	0	0	1
7	S043	驱动曲柄顶丝 hexagon socket sefscrew	0	0	1
8	S094	驱动曲柄座顶丝 driving levdr set screw	0	0	1
9	S093	驱动曲柄座螺钉 driving lever set screw	0	0	1
10	E03	卡簧 snapring	0	0	1

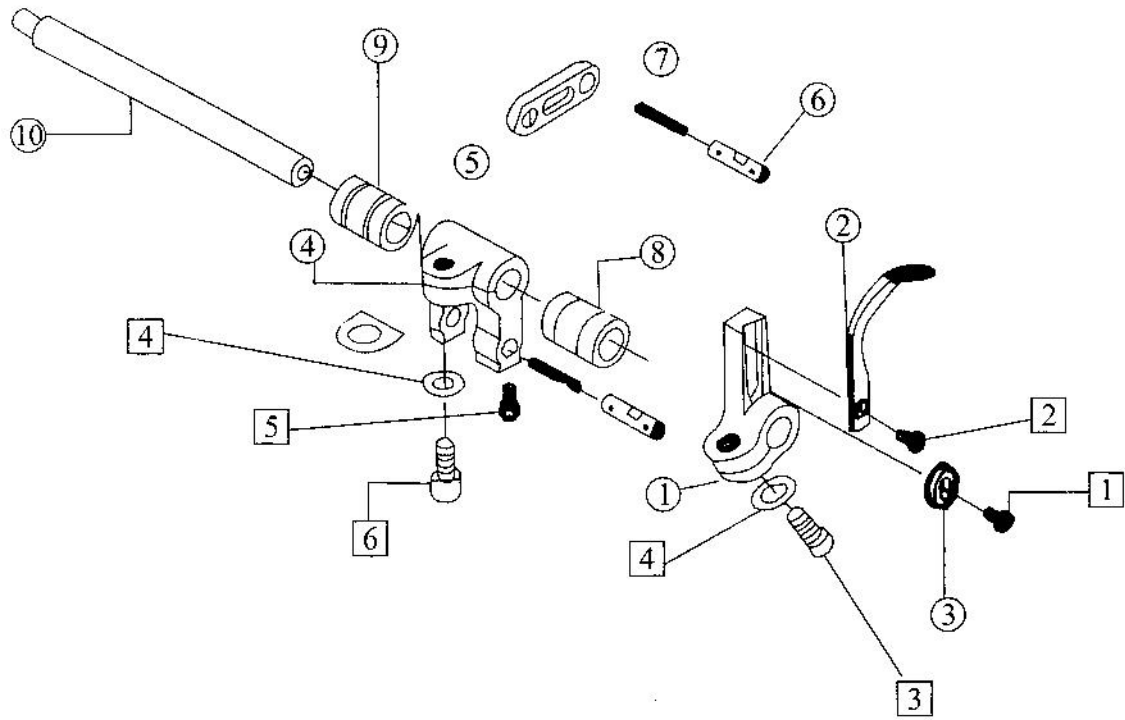
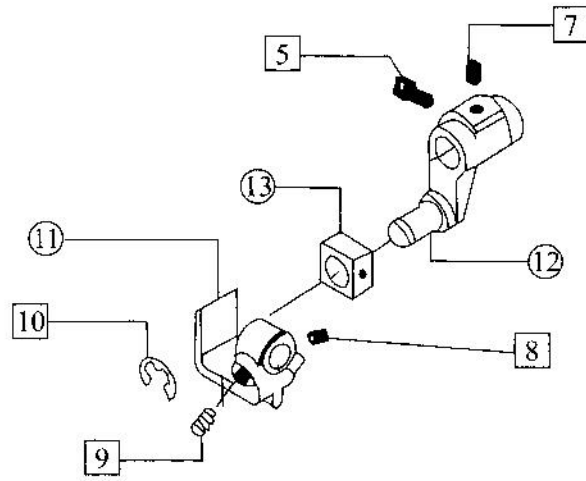

十、打线凸轮部分 / Cam assemblies

序号 Ref.No	零件编号 Part No.	名称	Name	数量 Amt. Req.		
				3	4	5
1	5M10-1	横轴连杆	bearing snap uing screw	0	0	1
2	5M10-2	连杆滚针轴承	bfeat guide camtop	0	0	1
3	5M10-3	轴承挡圈	shaft snap crank screw	0	0	1
4	5M10-4	曲柄销	shaft snap washer	0	0	1
5	5M10-5	横轴曲柄	crank adjusting pin wather	0	0	1
6	5M10-6	横轴曲柄轴	crank adjusting pin nut	0	0	1
7	5M10-7	横轴右套筒	holder finger nut	0	0	1
8	5M10-8	横轴左套筒	holder finger	0	0	1
9	5M10-9	油封	thread guide plate screw	0	0	1
10	5M10-10	打线凸轮	thread guide plate screw	0	0	1
11	5M10-11	导线板	thread guide finger set screw	0	0	1
12	5M10-12	过线板	thread guide for 2-thread screw	0	0	2
13	5M10-13	导线架	washer	0	0	1
14	5M10-14	波形垫圈	thread guide hook screw	0	0	1
15	5M10-15	限位板		0	0	1
16	5M10-16	过线环	thread guide hook	0	0	1
17	5M10-17	二眼过线板	2-thread thread guide	0	0	1
18	5M10-18	后导线板	rear thread guide finger set screw	0	0	1
19	5M10-19	导线管套	thread guide tube bushing	0	0	2
20	5M10-20	过线管	thread guide tube	0	0	1
21	5M10-21	过线管压板	thread guide tube olamp	0	0	2
22	5M10-22	压线器架	thread tension plate holder	0	0	1
23	5M10-23	夹线挺	holder spool	0	0	1
24	5M10-24	夹线片	holder spool	0	0	2
25	5M10-25	夹线簧	holder spool spring	0	0	1
26	5M10-26	调压螺母	presser nut	0	0	1
1	S002	轴承挡圈螺钉	bearing snap ring screw	0	0	2
2	S009	打线凸轮顶丝	cam set screw	0	0	2
3	S101	横轴曲柄螺钉	crank set screw	0	0	1
4	W12	横轴曲柄垫圈	crank washer	0	0	1
5	W06	曲柄调整销垫圈	crank adjusting pin wather	0	0	1
6	N02	曲柄调整螺母	crank adjusting pin nut	0	0	1
7	N03	夹线器架螺母	thread tension scrwe nut	0	0	1
8	S032	夹线器架螺钉	thread tension screw	0	0	1
9	S003	过线板螺钉	thread guide plate screw	0	0	2
10	S017	导线板螺钉	thread guide plate screw	0	0	1
11	S038	导线架固定螺钉	thread guide finger seet screw	0	0	1
12	S027	二眼过线板螺钉	thread guide for 2-thread screw	0	0	3
13	W11	垫圈	washer	0	0	1
14	S020	进线环螺钉	thread guide hook screw	0	0	1

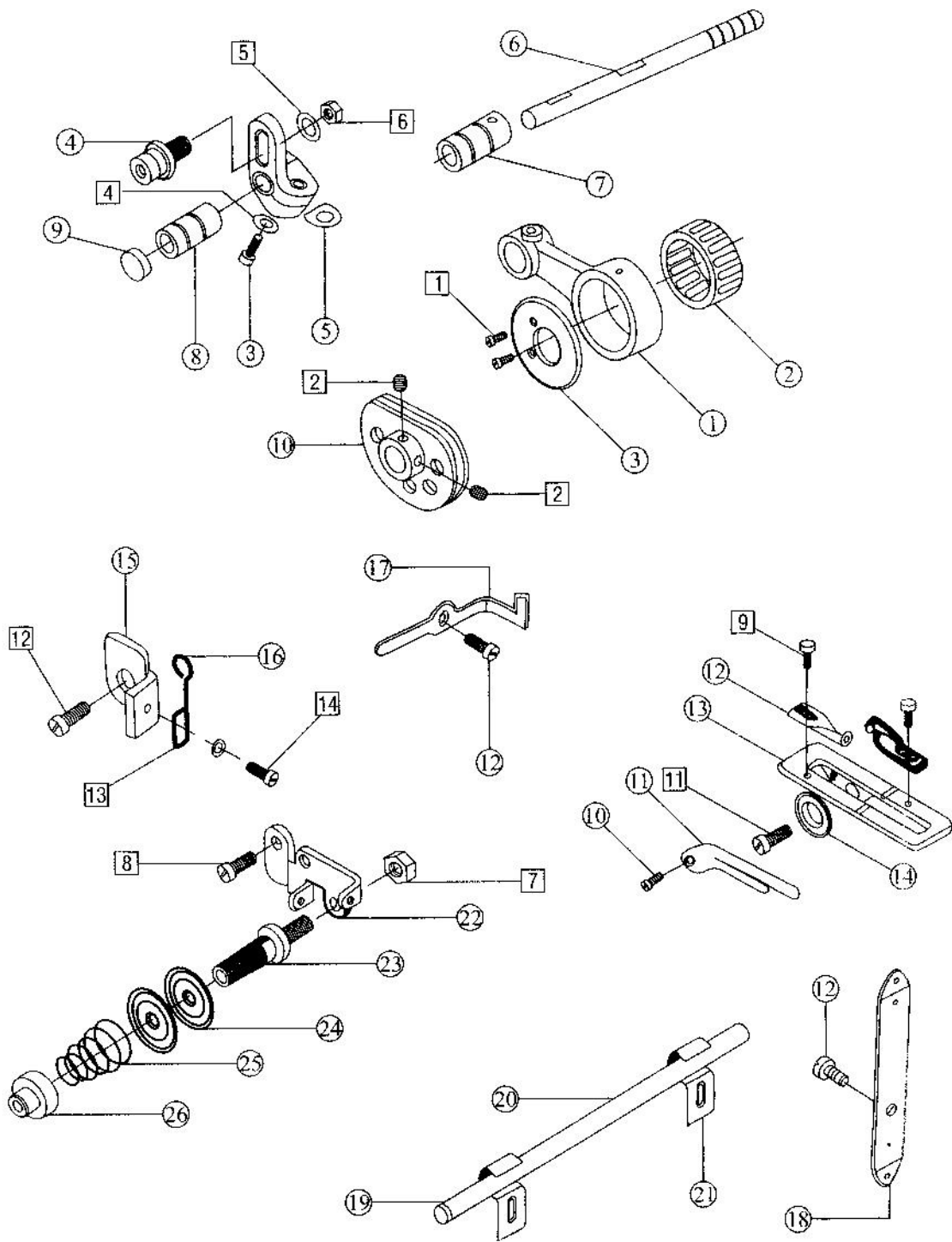

十一、差动送布部分 / Differential feed assemblies

序号 Ref.No	零件编号 Part No.	名称 Name	数量 Amt. Req.			
			3	4	5	
1	M11-1	送布调节器杆	stich length reglating shaft	1	1	1
2	M11-2	针距调节器簧	spring	1	1	1
3	M11-3	送布调节器油封	oil washer	1	1	1
4	M11-4	针距调节凸轮组件	stitch length regulating cam asm	1	1	1
5	M11-5	针距调节滑块	stitch length regulating block	1	1	1
6	M11-6	针距调节滑块压簧	stitch length regulating block spring	2	2	2
7	M11-7	针距凸轮	stitch length cam	1	1	1
8	M11-8	针距调节压板	stitch length regulating plate	1	1	1
9	M11-9	送布凸轮	feed lngth cam	1	1	1
10	M11-10	送布凸轮簧	feed cam spring	1	1	1
11	M11-11	送布凸轮座销	feed cam pin	1	1	1
12	M11-12	送布连杆	feed link	1	1	1
13	M11-13	滚动轴承	feed rod rolling pin bearing	1	1	1
14	M11-14	送布曲柄	feed crank	1	1	1
15	M11-15	差动连杆	differential link	1	1	1
16	M11-16	差动曲柄	differential crank	1	1	1
17	M11-17	销子	pin	1	1	1
18	M11-18	差动轴套筒	differential shaft bearing	1	1	1
19	M11-19	油封	oil seal	1	1	1
20	M11-20	挡圈	snap ring	1	1	1
21	M11-21	弹簧	spring	1	1	1
22	M11-22	垫圈	washer	1	1	1
23	M11-23	调节滑块	regalating block	1	1	1
24	M11-24	垫圈	washer	2	2	2
25	M11-25	送布凸轮座	feed cam	1	1	0
26	M11-26	垫圈	washer	1	1	1
27	M11-27	差动调节架	differential regulating holder	1	1	1
28	M11-28	调节螺钉	regulating screw	1	1	1
29	M11-29	卡簧	regulating screw spring	1	1	1
30	M11-30	差动调节杆	differential rigulating link	1	1	1
31	5M11-31	曲柄连杆凸轮	crank link cam	0	0	1
1	S096	差动连杆螺钉	differential link screw	1	1	1
2	S101	差动曲柄螺钉	differential crank screw	2	2	2
3	S028	挡圈螺钉	snap ring screw	1	1	1
4	W15	垫圈	washer	1	1	1
5	S01	垫圈	washer	2	2	2
6	S037	差动调节杆螺钉	differential positon screw	1	1	1
7	S012	卡簧螺钉	spring screw	1	1	1
8	S034	差动调节架紧固螺钉	differential set screw	1	1	1
9	S079	螺钉	screw	1	1	1
10	S027	差动调节螺钉	differential positop screw	1	1	1
11	S032	差动调节架螺钉	differential positop screw	1	1	1
12	S043	针距调节齿轮螺钉	stitch length	4	4	4
13	S008	送布凸轮调节螺钉	feed cam regulating screw	1	1	1
14	S011	送布凸轮螺钉	feed cam screw	1	1	1
15	S040	螺钉	screw	1	1	1
16	S036	针距调节压板螺钉	stitch length screw	1	1	1

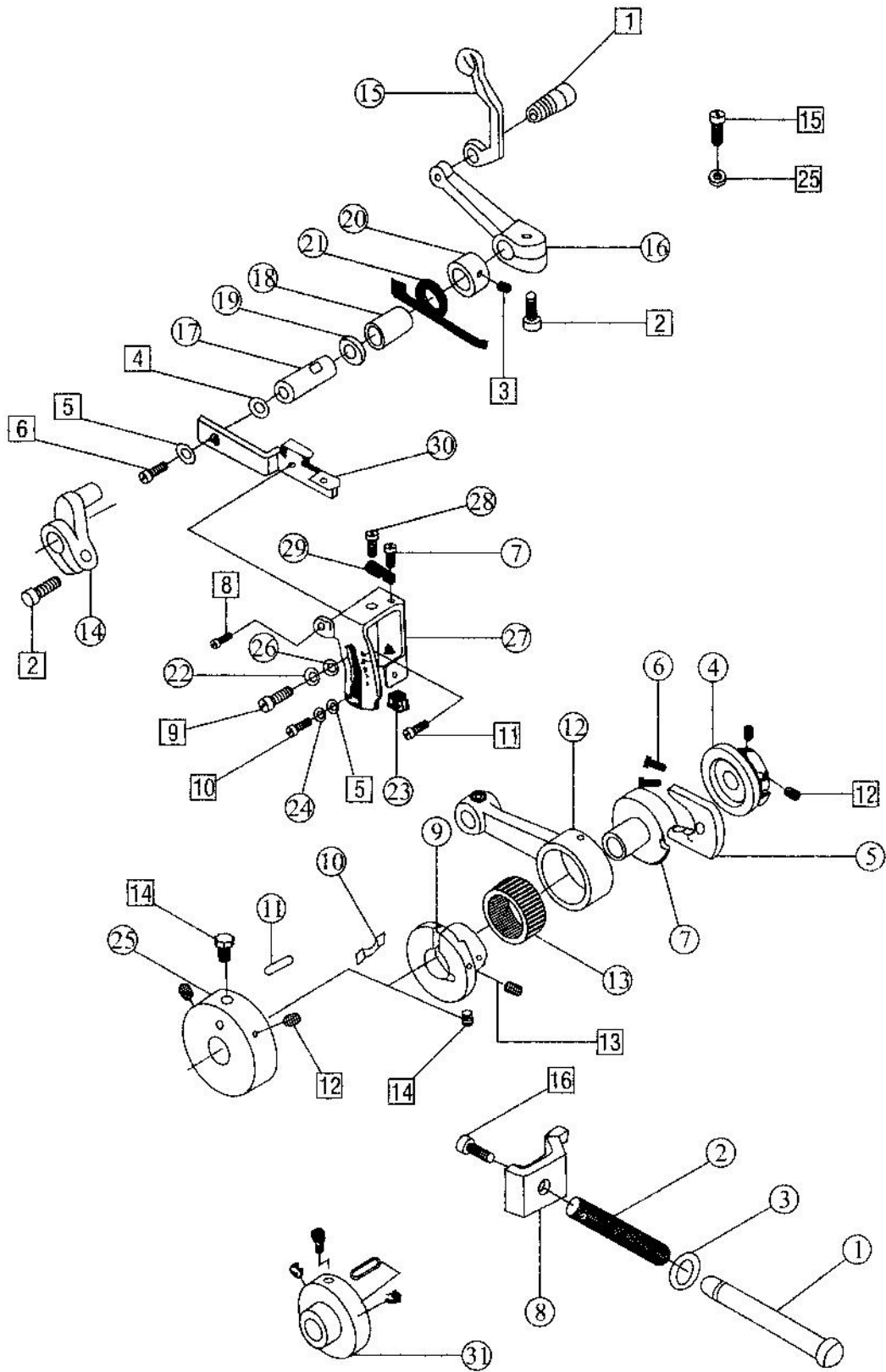

十二、抬牙送布部分 / Feed doy assemblies

序号 Ref.No	零件编号 Part No.	名称 Name	数量 Amt. Req.			
			3	4	5	
1	M12-1	牙连接板	doy link plate	1	1	1
2	M12-2	送布牙架	feed doy holder	1	1	1
3	M12-3	差动牙架	differential feed doy holder	1	1	1
4	M12-4	抬牙滑块	feed doy lift slide block	1	1	1
5	M12-5	抬牙滑块滚针轴承(已取消)	feed doy lift slide block shaft bearing	1	1	1
6	M12-6	卡簧	snap ring	1	1	1
7	M12-7	差动送布滑块	differential feed slide block	1	1	1
8	M12-8	滑块偏心轴	slide block eccentric shaft	1	1	1
9	M12-9	差动送布滑块偏心垫	differential feed slide block eccentric washer	1	1	1
10	M12-10	滑块偏心轴套筒	slide block eccentric shaft bushing	1	1	1
11	M12-11	送布轴	feed shaft	1	1	1
12	M12-12	送布轴左套筒	feed shaft bushing (left)	1	1	1
13	M12-13	送布轴右套筒	feed shaft bushing (right)	1	1	1
14	M12-14	送布调整曲柄	feed regulating crank	1	1	1
15	M12-15	垫圈	washer	1	1	1
16	M12-16	送布牙架连杆	feed doy holder link	1	1	1
17	M12-17	送布牙连杆套	feed doy holder link bushing	1	1	1
18	M12-18	送布牙架连杆套垫圈	differential feed doy holder link bushing	2	2	2
19	M12-19	曲柄滑块盖板	crank slide block cover	1	1	1
20	M12-20	曲柄滑块	crank slide block	1	1	1
21	M12-21	差动牙调节曲柄	feed regulating crank	1	1	1
22	M12-22	差动牙架连杆	differential feed doy holder link	1	1	1
23	M12-23	差动牙架连杆套	differential feed doy holder link bushing	1	1	1
24	M12-24	差动牙架连杆套垫圈	differential feed doy holder link bushing washer	2	2	2
25	M12-25	挡油板	screw oil plate	1	1	1
26	M12-26	牙架导轨	feed doy carrier connection rod	1	1	1
27	M12-27	密封圈	sealing connecting ring	1	1	1
28	M12-28	活动油封	adjustable oil seal	2	2	2
29	M12-29	密封导架	sealing connecting rod	1	1	1
30	M12-30	送布牙连杆偏心轴	feed doy link eccentric shaft	1	1	0
	5M12-30	送布牙连杆偏心轴	feed doy link eccentric shaft	0	0	1
31	M12-31	差动牙	differential dog	1	1	0
	5M12-31	差动牙	differential dog	0	0	1
32	M12-32	辅送布牙	main feed dog	1	1	0
	5M12-32	辅送布牙	main feed dog	0	0	1
33	M12-33	主送布牙	main feed dog	1	1	0
	5M12-33	主送布牙	main feed dog	0	0	1
1	S028	调牙套筒螺钉	regulating bushing	1	1	1
2	S005	辅助调牙套筒螺钉	feed dog bushing screw	1	1	1
3	S024	牙架接板螺钉	screw	1	1	1
4	S100	主送布牙螺钉	main feed dog screw	2	2	2
5	S029	左右牙叉连杆螺钉	dog holder link	2	2	2
6	S006	抬牙布曲柄螺钉	feed dog lift slide block screw	1	1	1
7	S101	右送布曲柄螺钉	feed shaft crank screw (right)	2	2	2

序号 Ref.No	零件编号 Part No.	名称 Name	数量 Amt. Rcq.		
			3	4	5
8	S012	左曲柄螺钉	5	5	5
9	S069	曲柄滑动盖螺钉	2	2	2
10	S034	牙叉叉块螺钉II	1	1	1
11	S046	牙叉叉块螺钉I	4	4	4
12	S031	螺钉	1	1	1
13	N02	右送布曲柄销螺母	1	1	1

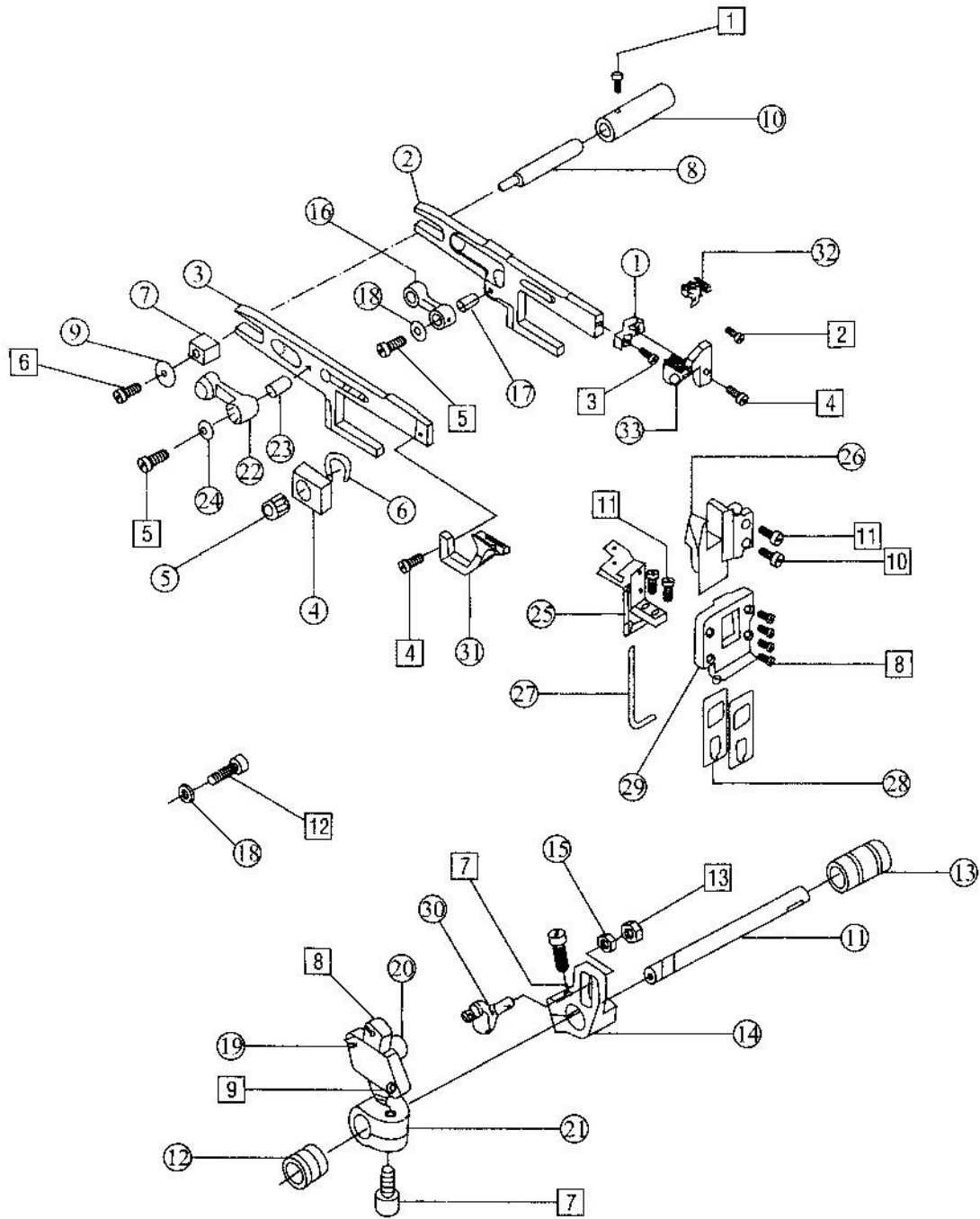

十三、剪切部分 / Trimming assemblies

序号 Ref.No	零件编号 Part No.	名称 Name	数量 Amt. Req.		
			3	4	5
1	M13-1	上刀连杆 upper knife driving connecting link	1	1	1
2	M13-2	上刀曲柄 upper knife crank	1	1	0
	5M13-2	上刀曲柄 upper knife crank	0	0	1
3	M13-3	曲柄销 crank pin	1	1	1
4	M13-4	上刀架轴 upper knife frame rock shaft	1	1	1
5	M13-5	上刀轴左套筒 upper knife frame rock shaft brushing left	1	1	1
6	M13-6	上刀轴右套筒 upper knife frame rock shaft bushing right	1	1	1
7	M13-7	垫圈 washer	1	1	1
8	M13-8	上刀座 upper knife holder	1	1	0
	5M13-8	上刀座 upper knife holder	0	0	1
9	M13-9	挡圈 snap ring	1	1	1
10	M13-10	上刀架轴圈 upper knife holder pin	1	1	1
11	M13-11	上刀 upper knife	1	1	1
12	M13-12	垫圈 washer	1	1	1
13	M13-13	下刀架 lower knife holder	1	1	0
	5M13-13	下刀架 lower knife holder	0	0	1
14	M13-14	下刀架套筒 lower knife holder bushing	1	1	1
15	M13-15	下刀架弹簧 lower knife holder spring	1	1	1
16	M13-16	下刀架挡板 lower knife holder	1	1	1
17	M13-17	下刀 lower knife	1	1	1
18	M13-18	下刀压板 lower knife holder locking plate	1	1	1
1	S057	挡圈螺钉 snapping screw	2	2	2
2	S010	上刀曲柄紧固螺钉 upper knife crank set screw	1	1	1
3	S043	上刀曲柄销螺钉 upper knife crank pin screw	1	1	1
4	S074	上刀连杆螺钉 upper knife connecting link screw	2	2	2
5	S046	上刀座螺钉 upper knife holder screw	1	1	1
6	S025	上刀螺钉 upper knife screw	1	1	1
7	S036	下刀压板螺钉 lower knife holder locking plate screw	1	1	1
8	S033	下刀架螺钉 lower knife holder locking plate screw	1	1	1
9	S045	下刀挡板螺钉 lower knife snap plate screw	1	1	1
10	S022	下刀挡板螺钉 lower knife snap plate screw	1	1	1
11	N01	下刀挡板螺母 lower knife snap plate screw	1	1	1

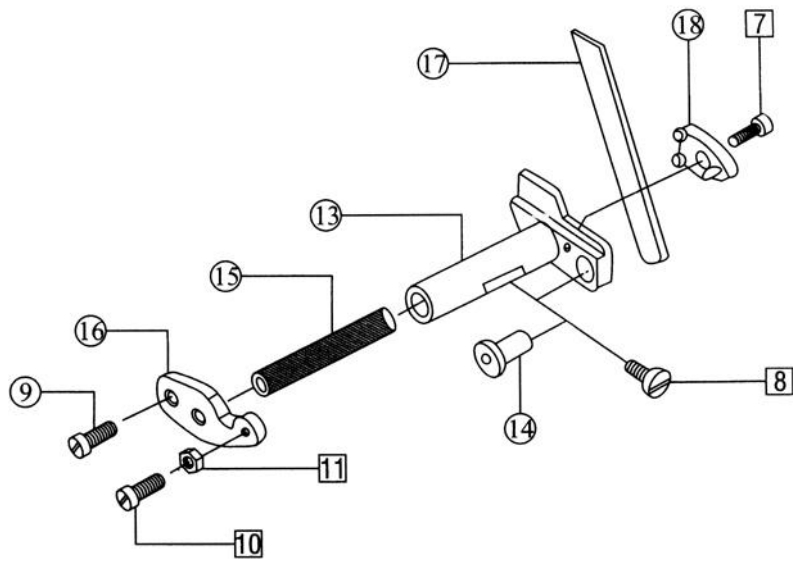
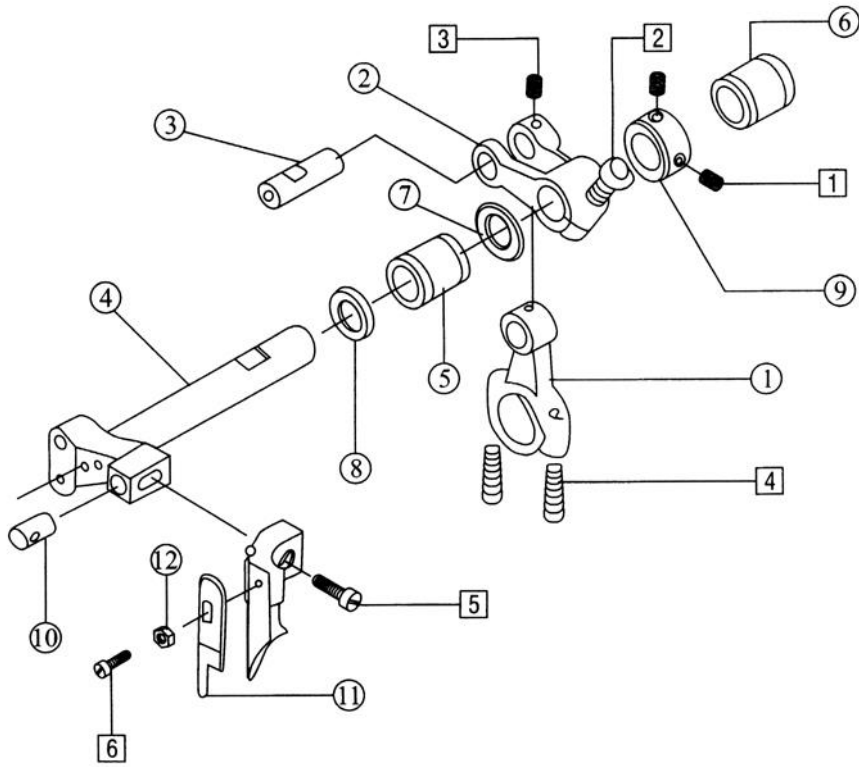

十四、压布部分 / Presser foot assemblies

序号 Ref.No	零件编号 Part No.	名称 Name	数量 Amt. Req.			
			3	4	5	
1	M14-1	压脚架	presser foot holder	1	1	1
2	M14-2	压脚轴套	presser foot shaft bushing	1	0	1
3	M14-3	压脚架销	presser foot holder pin	1	1	0
4	M14-4	压脚架轴	presser foot holder shaft	1	1	1
5	M14-5	压脚轴套筒	presser foot shaft bushing	1	1	1
6	M14-6	压脚轴挡圈	presser foot shaft snap ring	1	1	1
7	M14-7	抬挡簧	lever spring	1	1	1
8	M14-8	压脚曲柄	presser foot crank	1	1	1
9	M14-9	压脚柄	presser foot lifting lever	1	1	1
10	M14-10	压脚柄勾	hook	1	1	1
11	M14-11	压脚柄簧	spring	1	1	1
12	M14-12	割线刀	thread cutting knife	1	1	1
13	M14-13	压杆	presser barhead	1	1	1
14	M14-14	压杆簧	presser bar spring	1	1	1
15	M14-15	压杆螺钉	presser regulating screnl	1	1	1
16	M14-16	压脚扳手	presser foot lifting handle	1	1	1
17	M14-17	压力簧导销	presser foot lifting anh	1	1	1
18	M14-18	压脚扳手座	presser foot lifting handle bracket	1	1	1
19	M14-19	压杆套	presser bar bushing	1	1	1
20	M14-20	压力簧	presser foot liftin spring	1	1	1
21	5M14-21	压脚弹簧	presser foot	0	0	1
22	M14-22	压脚架连接板	presser foot holder conneting plate	1	1	1
23	M14-23	压脚接柄	presser foot holder	1	1	1
24	M14-24	压脚小舌头簧片	presser foot base	1	1	1
25	M14-25	压脚底板簧片	presser foot	1	1	1
26	M14-26	压脚架护罩	presser foot holder cover	1	1	1
27	M14-27	压脚组件	presser foot form	0	1	0
28	M14-28	压脚底板	presser foot base	0	1	0
29	M14-29	小压脚	lifter presser foot	0	1	0
30	M14-30	压脚组件	presser form	1	0	0
31	5M14-31	压脚组件	presser form	0	0	1
32	M14-32	抬压脚扳手销	presser foot lifting handle pin	1	1	1
1	S059	压脚柄勾螺钉	screw	1	1	1
2	S030	压脚柄勾定位螺钉	set screw	1	1	1
3	S011	压脚架连接板螺钉	presser foot holder commecting plate screw	2	2	2
4	S016	压脚接柄螺钉	presser foot holder screw	1	1	1
5	S004	压脚底板簧片螺钉	screw	1	1	1
6	S013	压脚舌头簧片螺钉	screw	1	1	1
7	S068	压脚脚曲柄螺钉	presser foot crand screw	1	1	1
8	N03	螺母	nut	1	1	1
9	S010	压脚曲柄定位螺钉	presser foot crand screw	1	1	1
10	S009	压脚轴挡套圈螺钉	presser foot shaft snap washer screw	3	3	3
11	S043	螺钉	screw	1	1	1
12	S071	割线刀螺钉	thread cutting knife screw	2	2	2
13	S007	压脚扳手螺钉	presser footlifting handle screw	1	1	1

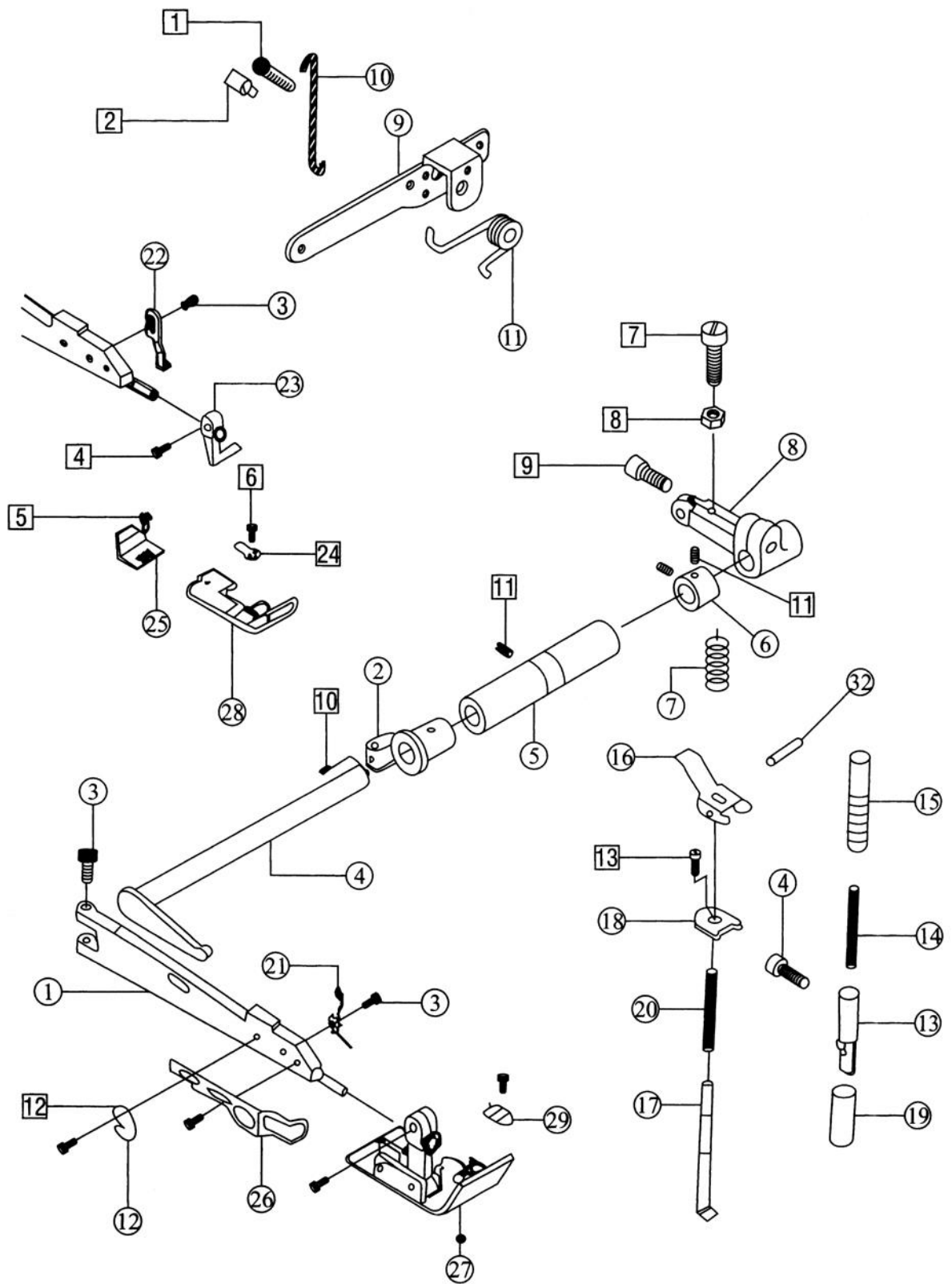

十五、润滑部分 / Lubrication assemblies

序号 Ref.No	零件编号 Part No.	名称	Name	数量 Amt. Req.		
				3	4	5
1	M15-1	油泵蜗轮	oil pump worm gear	1	1	1
2	M15-2	滑块五星齿轮套	oil pump rotator bushing	1	1	1
3	M15-3	油泵齿轮长轴	oil pump rptatpr shaft	1	1	1
4	M15-4	油泵五星齿轮	oil pump rotator	1	1	1
5	M15-5	油泵罩板	oil pump cover plate	1	1	1
6	M15-6	滤油器	oil cleaner	1	1	1
7	M15-7	滤油器接头	oil cljerner joint	1	1	1
8	M15-8	滤油器盖	oil clerner cover	1	1	1
9	M15-9	滤油器盖密封圈	oil clerner cover seal ring	1	1	1
10	M15-10	润滑提示	ingicaing plate	1	1	1
11	M15-11	油管	oil tube	1	1	1
12	M15-12	油管接头I	oil tube joint	1	1	1
13	M15-13	油管接头II	oil tube joint	1	1	1
14	M15-14	油管卡簧	oil tube shap ring	4	4	4
15	M15-15	润滑套	lubrcate bushing	1	1	1
16	M15-16	上配油器	upper screen	1	1	1
17	M15-17	下配油器	lower screen	1	1	1
18	M15-18	调节销	regulating pin	1	1	1
19	M15-19	油量显示座	oil show bracket	1	1	1
20	M15-20	油量显示器杆	oil show cleaner link	1	1	1
21	M15-21	油量显示支架	oil show cleaner guard	1	1	1
22	M15-22	油盘	oil pan	1	1	1
23	M15-23	油盘垫圈	oil pan washer	1	1	1
24	M15-24	油标不干胶	boug on with	1	1	1
25	M15-25	油标刻度	dial	1	1	1
26	M15-26	堵油垫圈	oil seal	1	1	1
27	M15-27	油盘磁铁	oil pan magnet	1	1	1
28	M15-28	油盘磁铁盖	oil pan magnet cover	1	1	1
29	M15-29	滤油网固定架	oil screen holder	1	1	1
30	M15-30	滤油网	oil screen felt	1	1	1
31	M15-31	油标	oil bouy	1	1	1
32	M15-32	油泵体组件	oil pump asm	1	1	1
33	M15-33	回油网		1	1	1
34	M15-34	油封		1	1	1
1	S057	油泵蜗轮螺钉	oil pamp worm gear screw	2	2	2
2	S024	滤油网螺钉	oil cleaner screw	3	3	3
3	S086	油管接头II螺钉	oil tube joint screw	1	1	1
4	S063	油管接头I螺钉	oil tube joint screw	1	1	1
5	S052	配油器螺钉	oil screen screw	1	1	1
6	S039	滤油器盖螺钉	oil screen cover screw	3	3	3
7	S042	油量显示器支架螺钉	oil boy finger screw	2	2	2
8	S037	油盘磁铁盖螺钉	oil pan magnet cover screw	1	1	1
9	S066	油盘放油螺钉	oil pan oil screw	1	1	1
10	S048	油泵螺钉	oil pump screw	1	1	1
11	S065	油泵体螺钉	oil pumps asm svrew	1	1	1

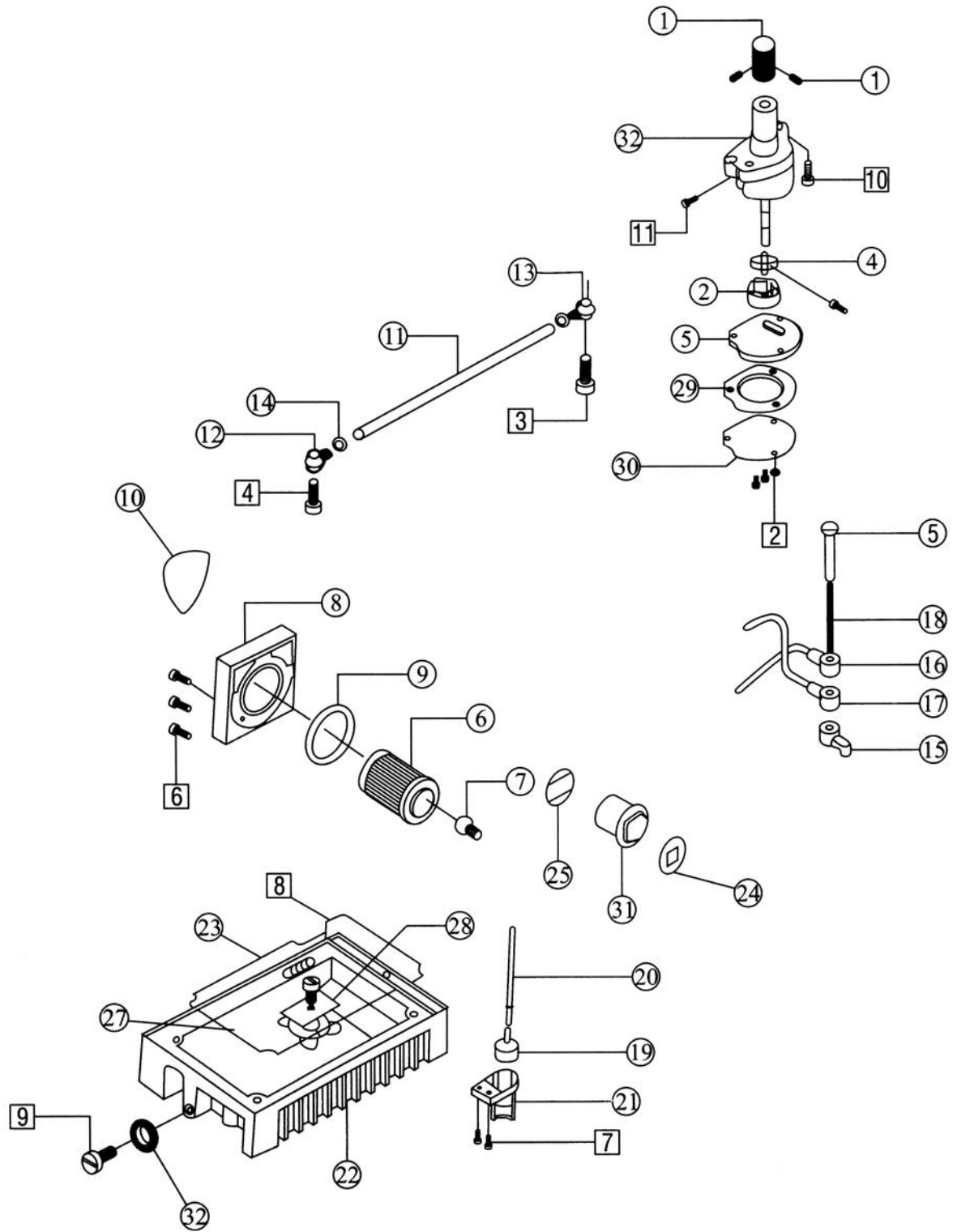

十六、送布挡料部分 / Feed snap assemblies

序号 Ref.No	零件编号 Part No.	名称 Name	数量 Amt. Req.		
			3	4	5
1	M16-1	油堵 oil seal	1	1	1
2	M16-2	机针冷却器 needle cooler	1	1	0
	5M16-2	机针冷却器 needle cooler	0	0	1
3	M16-3	油管 oil tube bracker	1	1	1
4	M16-4	硅油冷却油线 oil wick	1	1	1
5	M16-5	下硅油盒盖 lower oil cover	1	1	1
6	M16-6	下硅油盒 lower oil box	1	1	1
7	M16-7	油棉 oil felt	1	1	0
	5M16-7	油棉 oil felt	0	0	1
8	M16-8	油线 oil wick	1	1	1
9	M16-9	送料支架 cloth guide holder	1	1	1
10	M16-10	铰链板 oinge plate	1	1	1
11	M16-11	硅油棉块 oil felt block	1	1	
12	M16-12	铰链销 hinge pin	1	1	1
13	M16-13	铰链簧片 hinge spring	1	1	0
14	M16-14	挡料板 snap plate	1	1	1
15	M16-15	挡料板座 snap plate bracket	1	1	1
16	M16-16	挡料板 snap plate	1	1	0
	5M16-16	挡料板 snap plate	0	0	1
1	S018	挡料板螺钉 snap late screw	1	1	1
2	W09	垫圈 washer	1	1	1
3	S021	铰链簧螺钉 hinge spring screw	1	1	1
4	S026	铰链螺钉 hinge screw	2	2	2
5	W11	垫圈 washer	2	2	2
6	N03	螺母 nat	1	1	1
7	S047	送布支架螺钉 cloth guide holder screw	1	1	1
8	S037	机针冷却器螺钉 needle cooler screw	3	3	3

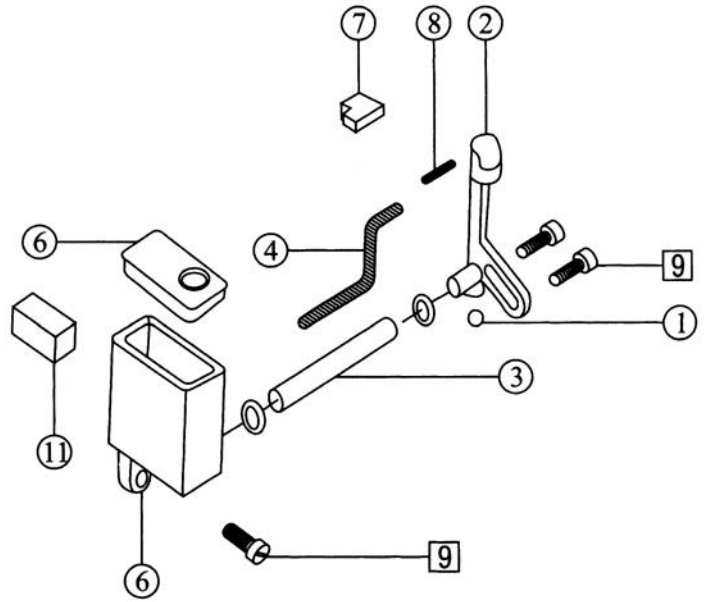
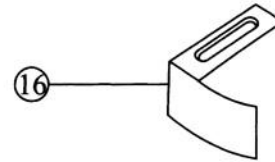
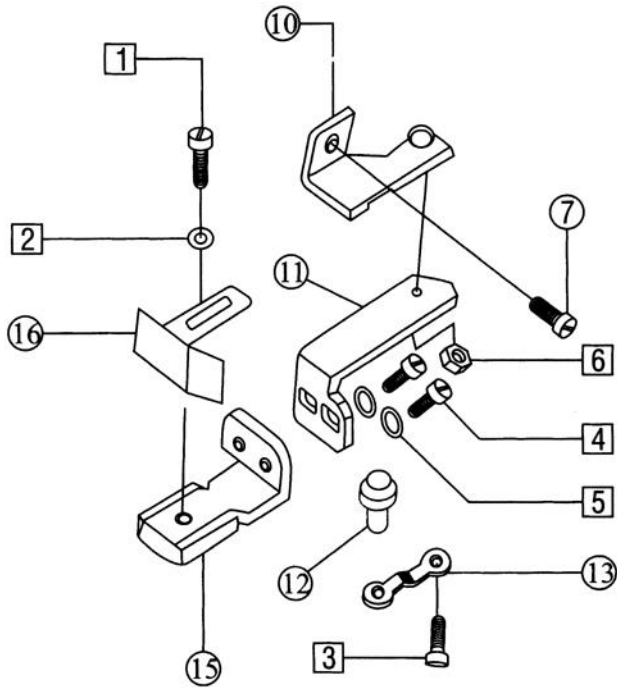

十七、线架部分 / Thread spool assemblies

序号 Ref.No	零件编号 Part No.	名 称 Name	数 量 Amt. Req.		
			3	4	5
1	M17-1	上管 upper thread column	1	1	1
2	M17-2	下管 lower thread column	1	1	1
3	M17-3	套 bushing	1	1	1
4	M17-4	长托线架 long thread spool troy bracket	1	1	1
5	M17-5	导线环 thread guide hook	4	4	4
6	M17-6	线托棒 spool pin	3	4	5
7	M17-7	线盘 spool tray	3	4	5
8	M17-8	线圈定位套 centering device	3	4	5
9	M17-9	棒架 clamp plate	1	1	1
10	M17-10	线盘垫 spool tray cushion	3	4	5
11	M17-11	导线棒 thread guide connecting bar	1	1	1
12	M17-12	因达器 thread guide joint	1	1	1
13	M17-13	固定板 thread stand holder	1	1	1
14	M17-14	导线棒 thread guide bar	1	1	1
15	M17-15	大导线棒 thread spool tray bracket	1	1	1
16	M17-16	过线板 thread guide plate	1	1	1
17	M17-17	托线架 thread spool tray bracket	1	1	1
18	M17-18	过线环 thread guide hook	3	3	3
19	M17-19	棒帽 rubber seal	1	1	1
1	S088	导线环螺钉 thread guide hook screw	4	4	4
2	N06	导线环螺母 thread guide hook screw	4	4	4
3	W02	导线环垫圈 thread guide washer	4	4	4
4	S075	棒架螺钉 clamp plate screw	3	3	3
5	S051	棒架螺钉 stick holder screw	1	1	1
6	N04	螺母 nut	8	8	8
7	W16	下管垫圈 lower washer	2	2	2
8	N05	螺母 nut	1	1	1
9	W05	垫圈 nut	4	4	4
10	S087	固定板螺钉 thread stand holder screw	1	1	1
11	S089	固定板连接螺钉 thread stand holder join screw	1	1	1

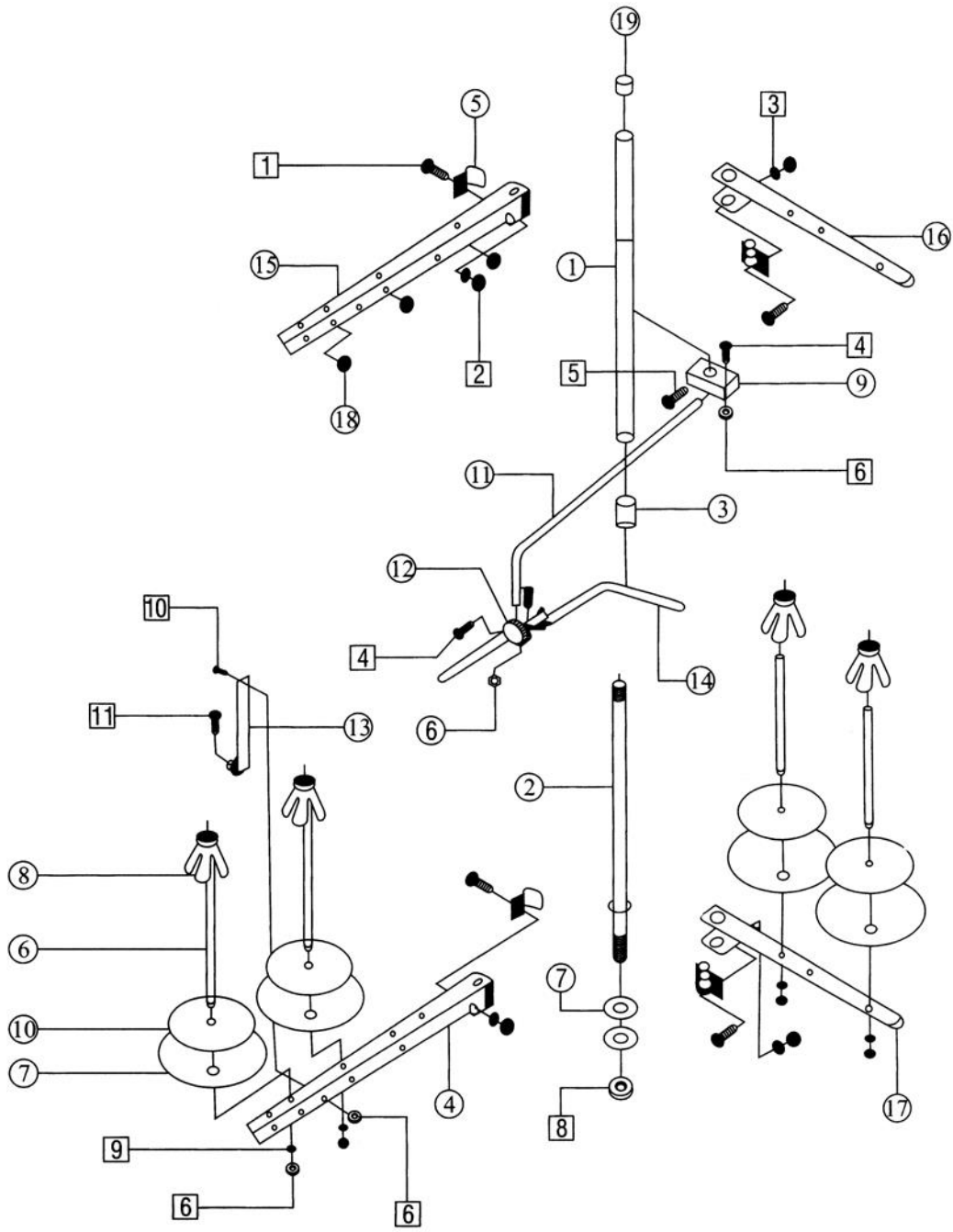

十八、托盘、排料部分 / Plater row material assemblies

序号 Ref.No	零件编号 Part No.	名称 Name	数量 Amt. Req.		
			3	4	5
1	M18-1	机头托盘	1	1	1
2	M18-2	减震垫组件			
3	M18-3	螺钉M8x55	4	4	4
4	M18-4	托盘螺钉固定头	4	4	4
5	M18-5	大垫圈	12	12	12
6	M18-6	托盘连接套	4	4	4
7	M18-7	排料槽座	1	1	1
8	M18-8	排料槽(1)	1	1	1
9	M18-9	排料槽(2)	1	1	1
10	M18-10	机头减震垫	1	1	1
1	S076	排料槽座螺钉	3	3	3
2	W13	排料槽垫圈	4	4	4
3	S077	排料槽螺钉	4	4	4

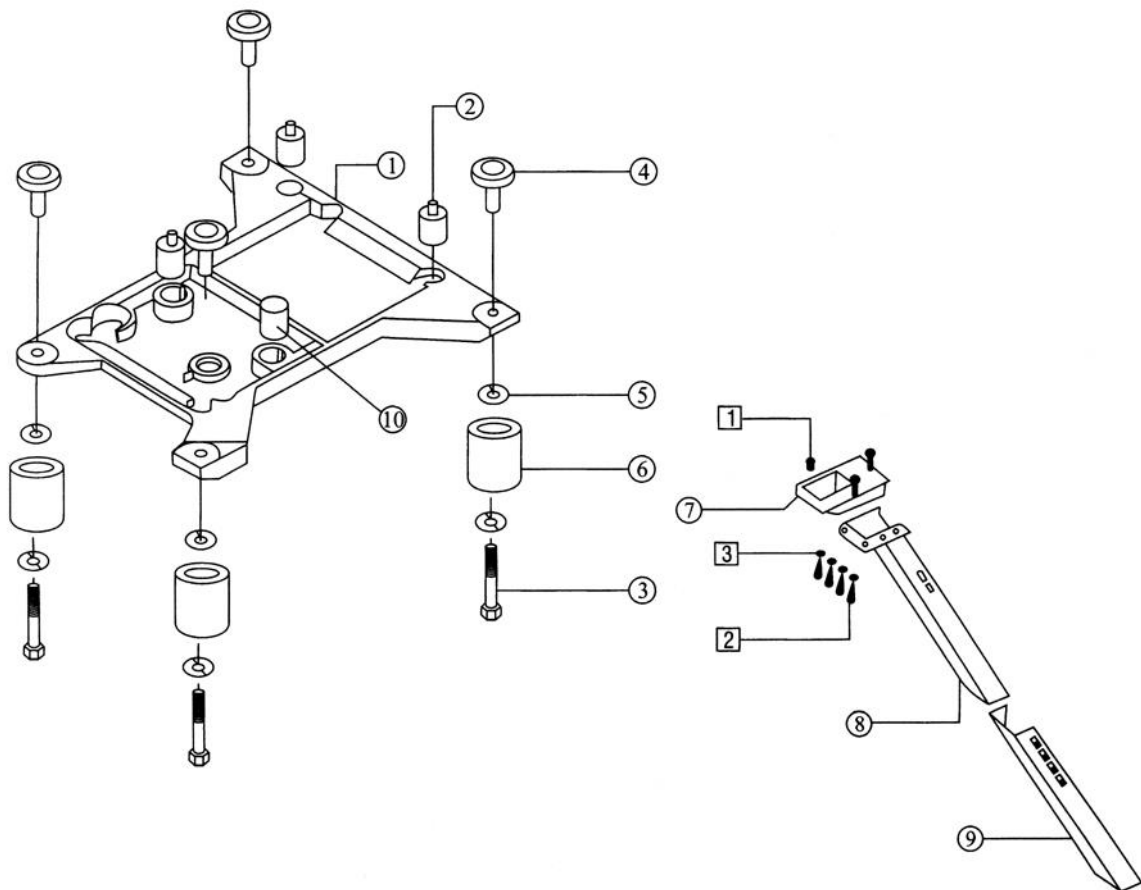

十九、随机附件部分 / Accessories assemblies



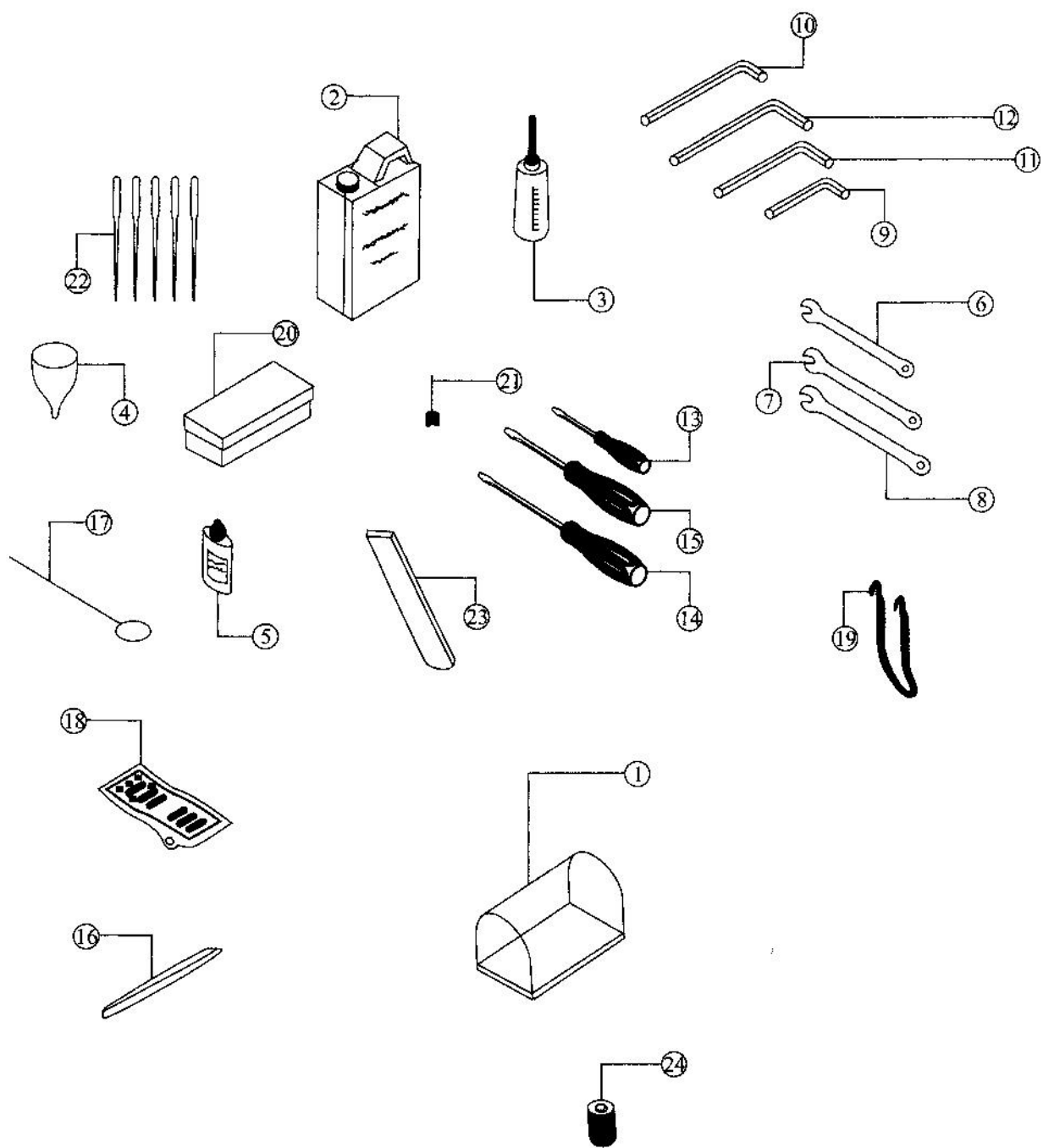







序号 Ref.No	零件编号 Part No.	名称 Name	数量 Amt. Req.			
			3	4	5	
1	M19-1	机罩	machine head cover	1	1	1
2	M19-2	油壶/1000cc	oil can/100cc	1	1	1
3	M19-3	注油壶	notes oil	1	1	1
4	M19-4	漏斗	tundish	1	1	1
5	M19-5	油壶/50cc	oil can/50cc	1	1	1
6	M19-6	扳手(6mm)	spanner	1	1	1
7	M19-7	扳手(7mm)	spanner	1	1	1
8	M19-8	扳手(8mm)	spanner	1	1	1
9	M19-9	内六角扳手(1.5mm)	cross screw driver	1	1	1
10	M19-10	内六角扳手(2mm)	cross screw driver	1	1	1
11	M19-11	内六角扳手(5mm)	cross screw driver	1	1	1
12	M19-12	内六角扳手(6mm)	cross screw driver	1	1	1
13	M19-13	螺丝刀(小)	screw driver	1	1	1
14	M19-14	螺丝刀(中)	screw driver	1	1	1
15	M19-15	螺丝刀(大)	screw driver	1	1	1
16	M19-16	镊子	tweezer	1	1	1
17	M19-17	金属线	metal guide	1	1	1
18	M19-18	脚踏板	presser foot base	1	1	1
19	M19-19	脚踏板链	presser foot base chain	1	1	1
20	M19-20	附件盒	affach nentbox	1	1	1
21	S009	顶针螺钉	thimble screw	1	1	1
22	DCX27	机针	needle	4	4	4
23	M11-19	下刀	lower knife	1	1	1
24	M13-6	过滤器	oil filter	1	1	1



737/747/757 系列专用件

	用 途											
机 型	用 途	针板 编号	主送布 牙编号		差 动牙 编号	压脚	上弯 针	针夹	垫圈	针杆 曲柄	下弯 针摆 动曲 柄	针号
737-3- 505F1 -04	下摆暗缝, 薄、中 厚物, 作暗缝卷边 作业	E784	D438	D674	H442	P152D-3	LP26	KG131-E	KJ10F	KF25-A	KJ09B-E	DC27#9
737-3- 504M1 -15	卷边缝, 薄物、适 用于女衬衫手帕等 装饰作业	E934	D438	D912	H442	P152D-A	LP26	KG131-E	KJ10F	KF25-A	KJ09B-E	DC27#9
737-3- 504M2 -04	一般缝纫, 薄、中 厚物, 用于基本缝 纫及西裤包边	E800	D440	D095	H445	P253E-4	LP26	KG131-E	KJ10F	KF25-A	KJ09B-E	DC27#11
747-4- 514M2 -24	一般缝纫, 薄、中 厚物, 用于针织内 衣、妇女、儿童等 服装肩缝, 腋缝等 作业	E919	D440	D095	H445	P253E-4	LP26	KG142-E	KJ13F	KF26-A	KJ11B-E	DC27#11*2
757-5- 516M2 -35	一般缝纫, 薄、中 厚物, 用于裤子、 睡衣、衬衫、运动 服等直缝作业, 缝 纫宽度 0.8cm	E982	D489	D502	H497	P504-A	LP26	KG153-E	KJ13F	KF26-A	KJ11B-E	DC27#14*2
757- 516M2 -55	一般缝纫, 极厚 物, 适于工作服, 女衬衫的侧旁缝和 肩缝等作业缝纫宽 度 1cm	E986	D489	D502	H500	P502-A	LP26	KG155-E	KJ13F	KF26-A	KJ11B-E	DC27#14*2
757-5- 516X2 -56	一般缝纫, 极厚 物适于牛仔服的 侧缝, 内档等作 业, 具有极厚物 用的双板式压脚	E870	D490	D502	H501	P960-A	LP38	KG155-E	KJ13F	KF26-A	KJ11B-E	DC27#18*2

COMPONENTS FOR 757, 747, 737 MODE

												
MODE	PURPOSE	NO.OF THROAT PLATE	NO.OF FEED DOG		NO.OF DIFFERENTIAL RATIO FEED DOG	PRESSER FOOT	UPPER LOOPER	NEEDLE CLAMP	WASHER	NEEDLE BAR SHAFT	LOWER LOOPER SHAFT	NO.OF NEEDLE
737-3-505F1-04	Front-concealed seam thin-middle-thick cloth	E784	D438	D674	H442	P152D-3	LP26	KG131-E	KJ10F	KF25-A	KJ09B-E	DC27#9
737-3-504M1-15	Crimping Seam thin cloth applicable to decoration of blouses and hand kerchiefs	E934	D438	D912	H442	P152D-A	LP26	KG131-E	KJ10F	KF25-A	KJ09B-E	DC27#9
737-3-504M2-04	General sewing for thin-middle-thick cloth, applicable to trousers piperation	E800	D440	D095	H445	P253E-4	LP26	KG131-E	KJ10F	KF25-A	KJ09B-E	DC27#11
747-4-514M2-24	General sewing for thin-middle-thick cloth, shoulder and armpit sewing knitting underwear and women and children clothes	E919	D440	D095	H445	P253E-4	LP26	KG142-E	KJ13F	KF26-A	KJ11B-E	DC27#11*2
757-5-516M2-35	General sewing for thin-middle-thick cloth, applicable to trousers bed-gown shirt	E982	D489	D502	H497	P504-A	LP26	KG153-E	KJ13F	KF26-A	KJ11B-E	DC27#14*2
757-516M2-55	General sewing for very thick cloth applicable to overalls blouses, side and shoulder seam sewing width 1cm	E986	D489	D502	H500	P502-A	LP26	KG155-E	KJ13F	KF26-A	KJ11B-E	DC27#14*2
757-5-516X2-56	General sewing for very thick cloth applicable to side seam or inside crotch with 2-board presser-bar	E870	D490	D502	H501	P960-A	LP38	KG155-E	KJ13F	KF26-A	KJ11B-E	DC27#18*2