

1. 机壳分组件/Machine frame&miscellaneous cover components

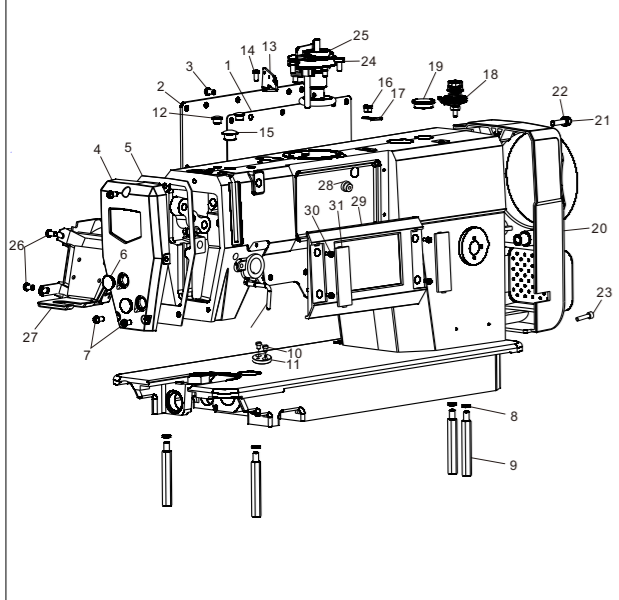

序号 Ref.No.	物料号 Part.No.	名称 Description	数量 Qty	备注 Remark
1	29.07.005	后窗板垫	1	
2	29.07.006	后窗板	1	
3	02.09.033	螺钉	13	
4	29.07.064	面板	1	
5	29.07.004	面板垫	1	
6	02.05.016	橡胶塞	2	
7	02.09.026	螺钉	3	
8	23.302	弹簧垫圈	4	
9	01.01.001	底座支柱	4	
10	02.09.035	螺钉	2	
11	02.05.003	卷边器座	1	
12	02.05.017	橡胶塞	2	
13	29.01.179	三眼过线板	1	
14	02.09.007	螺钉	1	
15	02.05.013	橡胶塞	1	
16	29.02.098	螺钉	2	
17	29.01.017	绕线切刀	1	
18	29.01.053Z2	绕线夹线器部件	1	
19	29.01.109	橡胶塞	1	
20	30.01.096	电机罩壳	1	
21	0000	垫圈	3	
22	29.02.097	螺钉	3	
23	0000	螺钉	3	
24	29.02.005	螺钉	3	
25	29.07.082	绕线器部件	1	
26	02.09.007	螺钉	1	
27	xxxxxx	机头灯部件	1	
28	29.01.229	橡胶塞	1	
29	30.01.091	显示屏部件	1	
30	29.07.087	螺钉	4	
31	30.01.091-2	盖板	2	

2. 上轴、挑线分组件/Main shaft&thread take-up components

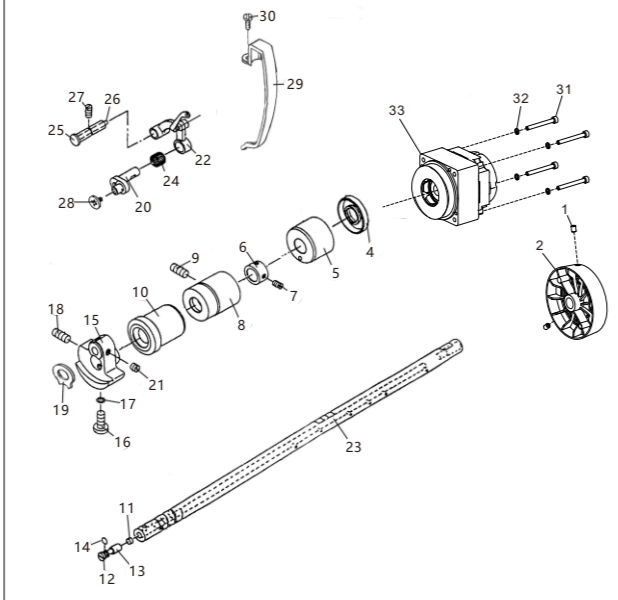

序号 Ref.No.	物料号 Part.No.	名称 Description	数量 Qty	备注 Remark
1	10020001	上轴	1	
2	10020002	上轴螺钉	2	
3	10020003	上轴	1	
4	10021000	上轴油封组件	1	
5	10020005	上轴后轴套	1	
6	10020006	上轴挡圈	1	
7	10020007	上轴挡圈螺钉	2	
8	10020008	上轴中轴套	1	
9	10020009	上轴中轴套螺钉	1	
10	10020010	上轴前轴套	1	
11	10020011	曲柄油量调节阀	1	
12	10020012	曲柄油量调节阀销	1	
13	10020013	曲柄油量调节阀圈	1	
14	10020014	曲柄油量调节阀O型圈	1	
15	10020015	针杆曲柄	1	
16	10020016	针杆曲柄定位螺钉	1	
17	10020017	定位螺钉O型圈	1	
18	10020018	针杆曲柄紧固螺钉	1	
19	10020019	针杆曲柄护板	1	
20	10020020	挑线曲柄	1	
21	10020021	挑线曲柄定位螺钉	2	
22	10020022	挑线杆分母件	1	
23	10020023	挑线杆防油塞	1	
24	10020024	挑线杆轴衬轴承	1	
25	10020025	挑线杆轴衬	1	
26	10020026	挑线杆轴衬油封	1	
27	10020027	挑线杆轴衬螺钉	1	
28	10020028	挑线曲柄左螺母	1	
29	10020029	挑线杆螺母	1	
30	10020030	挑线杆护罩螺钉	1	
31	29.07.087	螺钉	4	
32	23.303	弹簧垫圈	4	
33	30.01.094	上轴电机	1	

3. 针杆分组件 Needle bar components

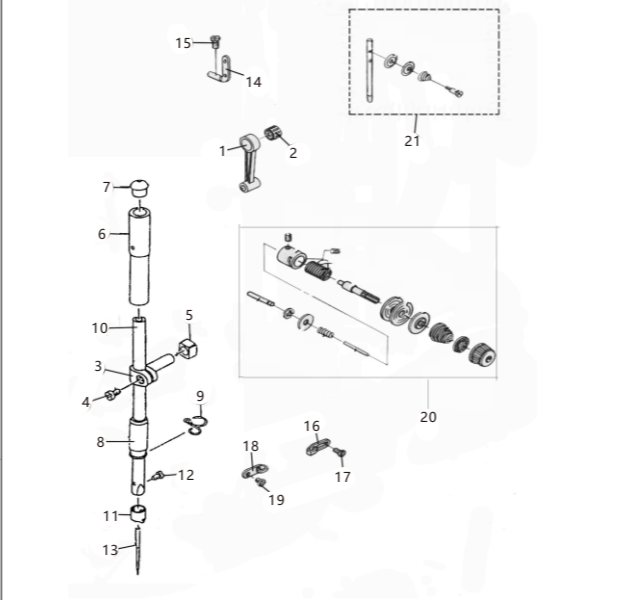

序号 Ref.No.	物料号 Part.No.	名称 Description	数量 Qty	备注 Remark
1	10030001	针杆连杆	1	
2	10030002	针杆连杆衬套	1	
3	10030003	针杆连接柱	1	
4	10030004	针杆连接柱螺钉	1	
5	10030005	针杆连接柱滑块	1	
6	10030006	针杆上轴套	1	
7	10030007	针杆上轴套孔塞	1	
8	10030008	针杆下轴套	1	
9	10030009	针杆下轴套线勾	1	
10	10030010	针杆	1	
11	10030011	针杆线勾	1	
12	10030012	支杆螺钉	1	
13	10030013	机针	1	
14	10030014	二眼线勾	1	
15	10030015	二眼线勾螺钉	1	
16	10030016	右线勾	1	
17	10030017	右线勾螺钉	1	
18	10030018	左线勾	1	
19	10030017	左线勾螺钉	1	
20	10031000	尖刺器部件	1	
21	10032000	过线器部件	1	

6. 送料分组件/Feed Mechanism Components

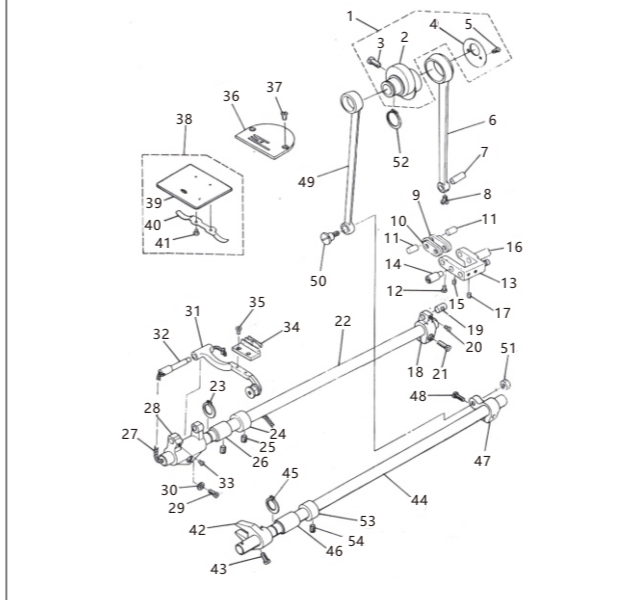

序号 Ref.No.	物料号 Part.No.	名称 Description	数量 Qty	备注 Remark
31	10051001	牙架	1	
32	10050057	送料前轴衬套	1	
33	10050058	送料前轴衬套	1	
34	10050058	送料前轴衬套	1	
35	10050059	送料前轴衬套	2	
36	10050059	送料前轴衬套	1	
37	10050060	送料前轴衬套	2	
38	10050060	送料前轴衬套	1	
39	10052001	送料前轴衬套	1	
40	10052002	送料前轴衬套	1	
41	10052003	送料前轴衬套	2	
42	10050067	送料前轴衬套	1	
43	10050068	送料前轴衬套	1	
44	10050069	送料前轴衬套	1	
45	10050048	送料前轴衬套	1	
46	10050071	送料前轴衬套	1	
47	10050072	送料前轴衬套	1	
48	10050073	送料前轴衬套	1	
49	10050074	送料前轴衬套	1	
50	10050075	送料前轴衬套	1	
51	10050076	送料前轴衬套	1	
52	10050077	送料前轴衬套	1	

7. 送布调节分组件/Cloth feeding adjustment Components

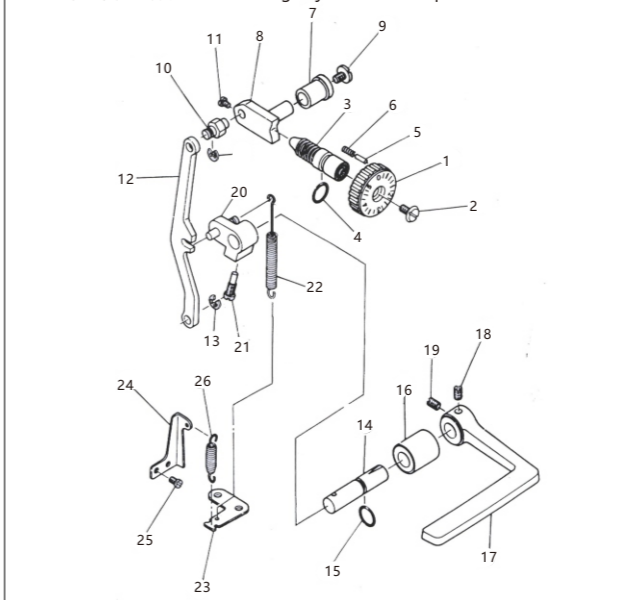

序号 Ref.No.	物料号 Part.No.	名称 Description	数量 Qty	备注 Remark
1	10050080	送料前轴衬套	1	
2	10050081	送料前轴衬套	1	
3	10050082	送料前轴衬套	1	
4	10050083	送料前轴衬套	1	
5	10050084	送料前轴衬套	1	
6	10050085	送料前轴衬套	1	
7	10050087	送料前轴衬套	1	
8	10050088	送料前轴衬套	1	
9	10050088	送料前轴衬套	1	
10	10050089	送料前轴衬套	1	
11	10050090	送料前轴衬套	1	
12	10050091	送料前轴衬套	1	
13	10050092	送料前轴衬套	2	
14	10050093	送料前轴衬套	1	
15	10050094	送料前轴衬套	1	
16	10050095	送料前轴衬套	1	
17	10050096	送料前轴衬套	1	
18	10050097	送料前轴衬套	1	
19	10050099	送料前轴衬套	1	
20	10053000	送料前轴衬套	1	
21	10050100	送料前轴衬套	1	
22	10050101	送料前轴衬套	1	
23	10050102	送料前轴衬套	1	
24	10050103	送料前轴衬套	1	
25	10050104	送料前轴衬套	2	
26	10050105	送料前轴衬套	1	

8. 润滑分组件/Lubrication Components

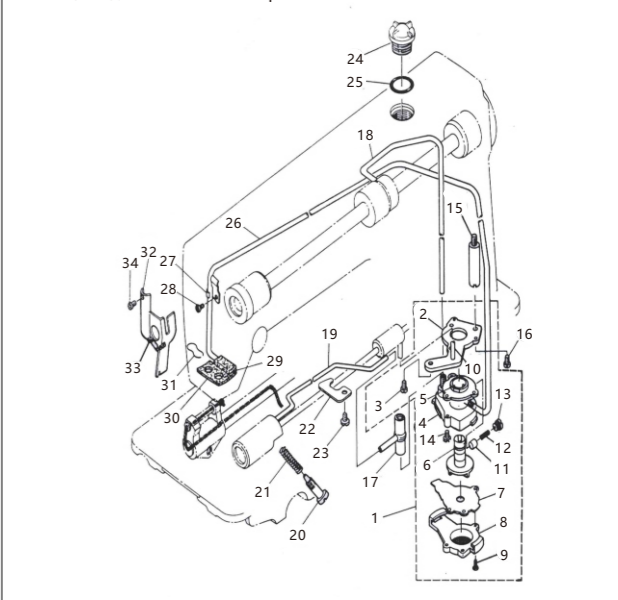

序号 Ref.No.	物料号 Part.No.	名称 Description	数量 Qty	备注 Remark
1	10061000	油泵部件	1	
2	10061001	油泵安装板	1	
3	10061002	油泵安装螺钉	3	
4	10061003	油泵体	1	
5	10061004	油泵体衬套	1	
6	10061005	油泵叶轮	1	
7	10061006	叶轮托板	1	
8	10061007	油泵盖	1	
9	10061008	油泵盖螺钉	3	
10	10060001	下轴衬套	1	
11	10061009	回油柱套	1	
12	10061010	柱塞弹簧	1	
13	10061011	柱塞螺钉	1	
14	10061012	油泵螺钉	1	
15	10060002	油泵支柱螺钉	1	
16	10050006	螺栓连接螺钉	1	
17	10061013	供油管接头	1	
18	10060007	回油管衬套	1	
19	10060005	旋梭供油管	1	
20	10060006	旋梭油量调节螺钉	1	
21	10060007	旋梭油量调节簧	1	
22	10060008	旋梭供油管压板	1	
23	10060009	压板螺钉	1	
24	10060010	油窗	1	
25	10060011	油窗O型圈	1	
26	10060012	回油管	1	
27	10060013	回油管夹	1	
28	10020030	回油管夹螺钉	1	
29	10060015	回油除尘毡	1	
30	10060016	回油毡	1	
31	10060017	回油毡夹	1	
32	10060018	面部防油板	1	
33	10060019	防油板油线	1	
34	10060020	防油板螺钉	1	

4. 压脚分组件/Hang Lifter Components

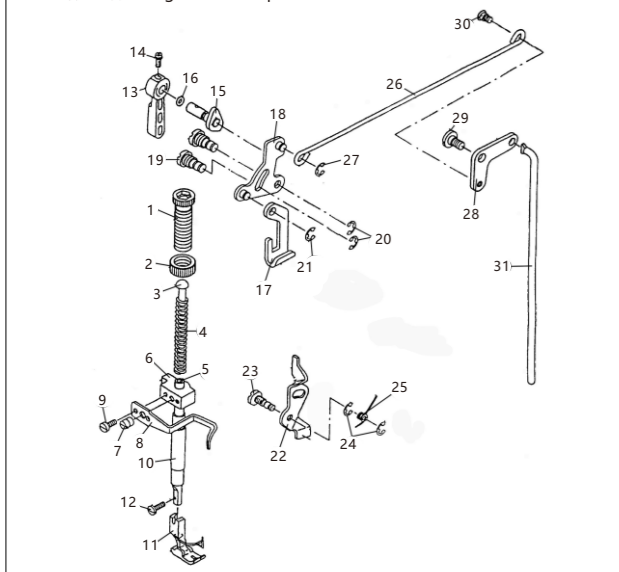

序号 Ref.No.	物料号 Part.No.	名称 Description	数量 Qty	备注 Remark
1	10040001	调压螺钉	1	
2	10040002	调压螺母	1	
3	10040003	调压导杆	1	
4	10040004	调压弹簧	1	
5	10040005	压杆导架	1	
6	10040005	压杆	1	
8	10040008	挑线调节勾	1	
7	10040007	压杆导架螺钉	1	
9	10040009	挑线调节勾螺钉	2	
10	10040010	压杆轴套	1	
11	10041000	压脚组件	1	
12	10040012	压脚螺钉	1	
13	10040013	压脚抓手	1	
14	10040014	压脚抓手螺钉	1	
15	10040015	压脚抓手凸轮	1	
16	10040016	压脚抓手轴O型圈	1	
17	10040017	压脚升降板	1	
18	10040018	压脚升降杆部件	1	
19	10040019	前杠杆螺套	2	
20	10040020	前杠杆螺套开口挡圈	3	
21	10040021	升降杆螺套制开挡圈	1	
22	10040022	挑线顶板	1	
23	10040023	挑线顶板螺钉	1	
24	10040024	挑线顶板螺母	2	
25	10040025	挑线顶板复位弹簧	1	
26	10040026	挑线顶板	1	
27	10040027	挑线顶板	1	
28	10040028	挑线顶板后杠杆	1	
29	10040029	后杠杆轴衬套	1	
30	10040030	后杠杆轴衬套	1	
31	10040031	挑线顶板	1	

5. 勾线分组件/Hook of driving shaft Components

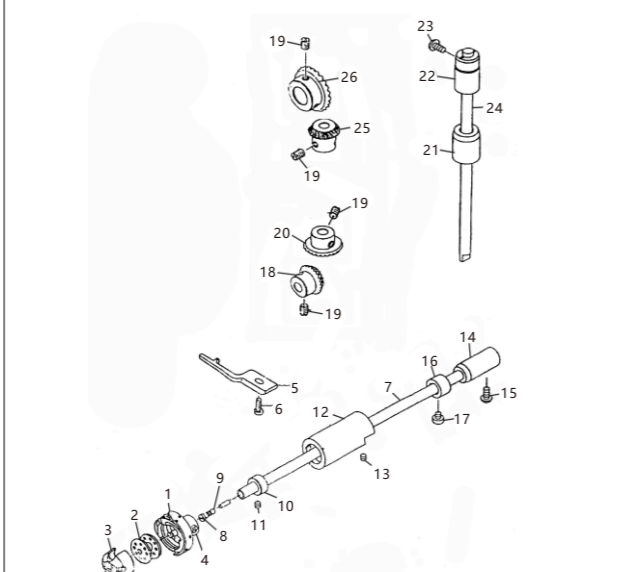

序号 Ref.No.	物料号 Part.No.	名称 Description	数量 Qty	备注 Remark
1	10050001	旋梭	1	
2	10050003	旋梭壳	1	
3	10050002	旋梭芯	1	
4	10050004	旋梭壳螺母	2	
5	10050005	旋梭壳套	1	
6	10050006	旋梭定位勾螺钉	1	
7	10050007	下轴	1	
8	10050008	下轴限油芯螺钉	1	
9	10050009	下轴限油芯	1	
10	10050010	下轴挡油圈	1	
11	10050011	下轴挡油圈螺钉	2	
12	10050012	下轴前轴套部件	1	
13	10050009	下轴前轴套螺钉	1	
14	10050014	下轴后轴套	1	
15	10010006	下轴后轴套螺钉	1	
16	10050016	下轴挡圈	1	
17	10050017	下轴挡圈螺钉	2	
18	10050018	下轴全齿轮(小)	1	
19	10050019	伞齿螺钉	8	
20	10050020	整轴下伞齿轮(大)	1	
21	10050021	整轴下轴套	1	
22	10050022	整轴上轴套	1	
23	10050023	整轴上轴套螺钉	1	
24	10050024	整轴	1	
25	10050025	整轴上伞齿轮(小)	1	
26	10050026	整轴上伞齿轮(大)	1	

6. 送料分组件/Feed Mechanism Components

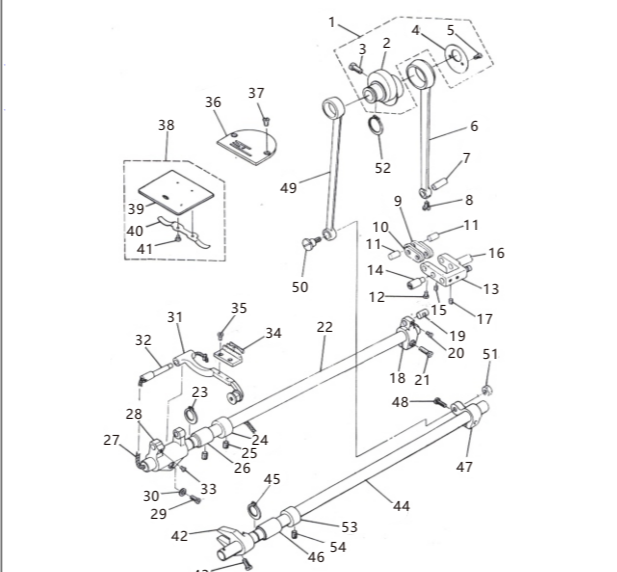

序号 Ref.No.	物料号 Part.No.	名称 Description	数量 Qty	备注 Remark
1	10050001	送料前轴衬套	1	
2	10050027	送料前轴衬套	1	
3	10050028	送料前轴衬套	2	
4	10050029	送料前轴衬套	1	
5	10050030	送料前轴衬套	4	
6	10050031	送料前轴衬套	1	
7	10050032	送料前轴衬套	1	
8	10050033	送料前轴衬套	2	
9	10050034	送料前轴衬套	2	
10	10050035	送料前轴衬套	2	
11	10050036	送料前轴衬套	2	
12	10050037	送料前轴衬套		