



# TYPICAL

---

## GC321 SERIES

MULTI-NEEDLE CYLINDER BED  
DOUBLE CHAIN STITCH MACHINE

INSTRUCTION BOOK  
PARTS CATALOGUE

---

XI'AN TYPICAL INDUSTRIES CO.,LTD.

# CONTENTS

1. SPECIFICATIONS .....	1
2. NEEDLES AND THREADING THE MACHINE.....	2
3. MACHINE SPEED.....	7
4. LUBRICATION.....	7
5. SEWING MACHINE INSTALLATION.....	9
6. TIMING OF THE LOOPER TO THE NEEDLES.....	10
7. TIMING OF THE RETAINER LOOPER.....	11
8. ADJUSTING THE NEEDLE GUARD.....	12
9. ADJUSTING THE FEED DOG AND STITCH LENGTH.....	12
10. ADJUSTING THE PRESSER FOOT.....	14
11. ADJUSTING THE REAR PULLER DEVICE.....	15
12. ADJUSTING THE STITCH FORMATION.....	16
13. CLEANING THE MACHINE.....	17

Thank you for your purchasing our company's machine.

Read and study this instruction manual carefully before beginning any of the procedures and save it for later use.

1. This instruction manual describes adjustments and maintenance procedures on this machine.
2. Before starting the machine, check to make sure the pulley cover, safety cover, etc. are secured.
3. Before adjusting, cleaning, threading the machine or replacing the needle, be sure to turn off the power.
4. Never start the machine with no oil in the reservoir.
5. Refer to the parts list as well as this instruction manual before maintenance.
6. The contents described in this instruction manual are subject to change without notice.

## 1. SPECIFICATIONS

### 1 - 1 STITCH TYPE

401 double chainstitch machines

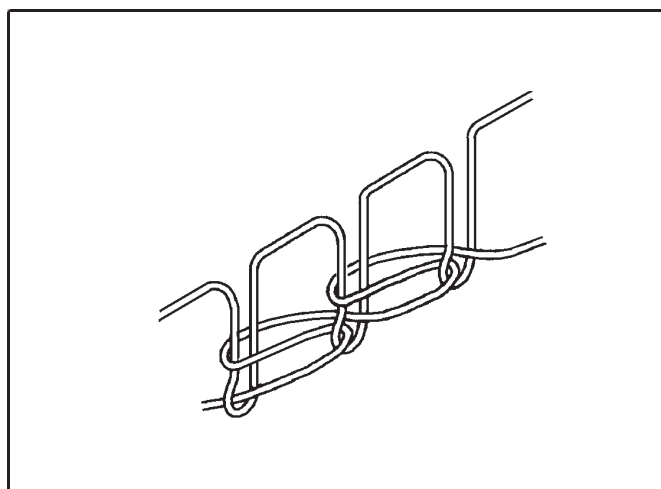

### 1 - 2 MODELS

Model		321 -4	321 -6	321 -12
No. of needles		2 -4	5 -6	7 -12
No. of threads	Needle thread	2 -4	5 -6	7 -12
	Looper thread	2 -4	5 -6	7 -12
Puller width		55mm	88mm	
Min. gauge width		4.76mm (3/16 inch)		
Max. gauge width		50mm	70mm (without thread trimmer) 76.2mm (with thread trimmer)	

# 1 - 3 DIAGRAMMATIC SKETCH OF THE SERIES

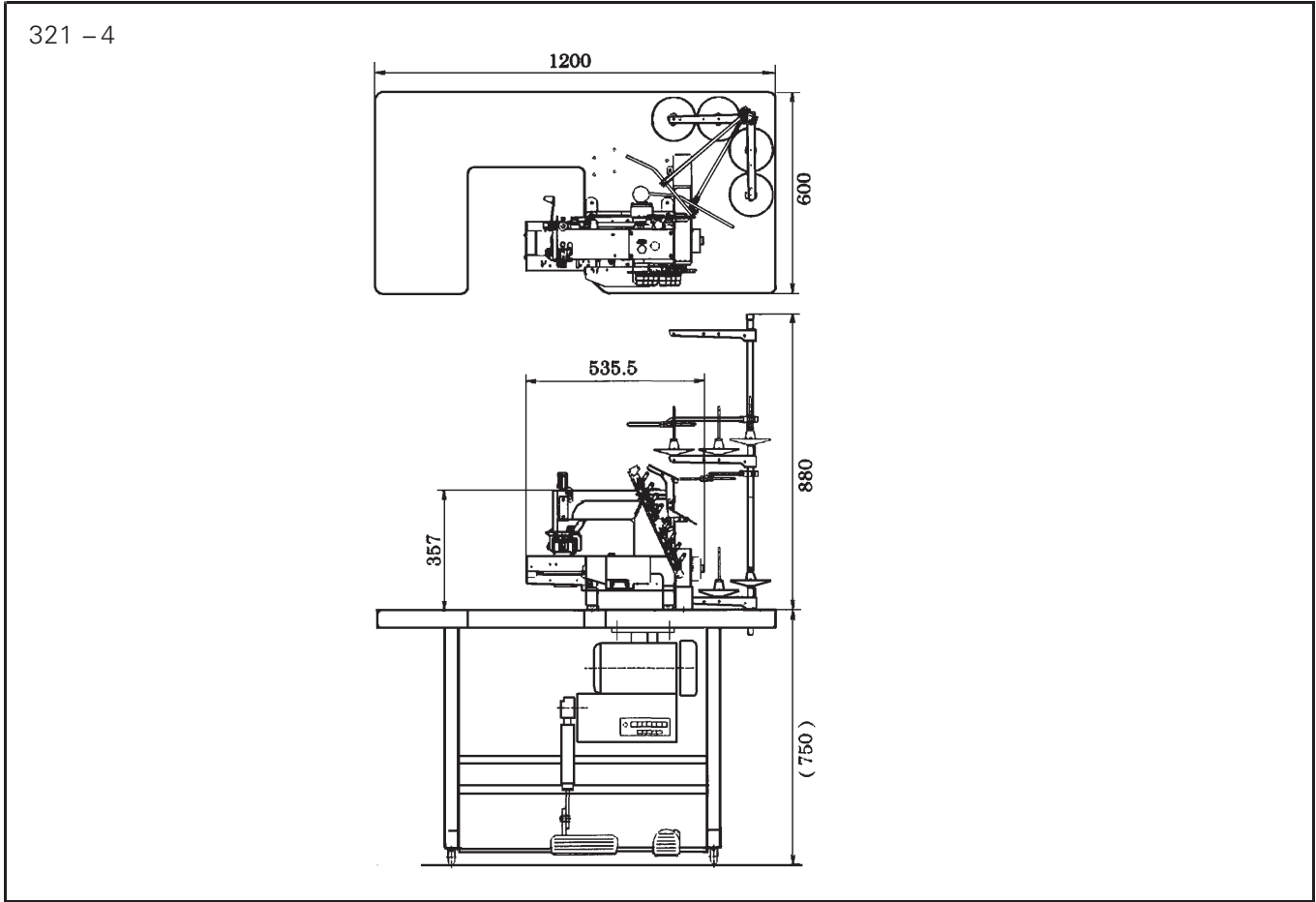

## 2. NEEDLE AND THREADING THE MACHINE

### 2 - 1 NEEDLES

DV x57 of Schmetz or organ

Select the proper needle for the fabric and thread to be used.

<Needle count comparison table>

Schmetz DVX57	Nm75	Nm80	Nm90	Nm100
Organ DVX57	#11	#12	#14	#16

### 2 - 2 REPLACING THE NEEDLE

When replacing the needle, check the needle carefully to see that the scarf is turned to the left (see the illustration.)

NOTE:

Be sure to turn off the machine before replacing the needle. A clutch motor continues running for a while after the machine is turned off. Therefore keep on pressing the pedal until the machine stops.

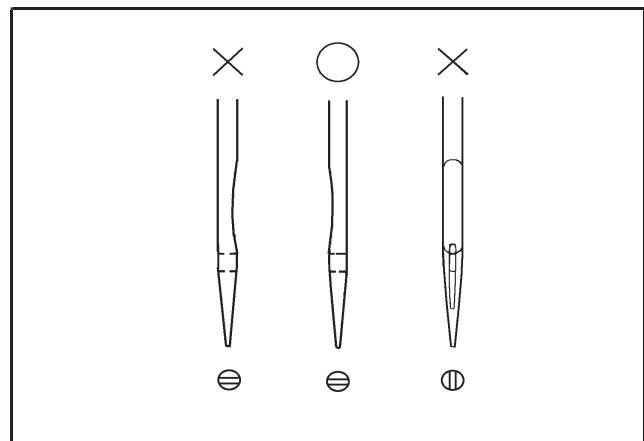

## 2 – 3 TO THREAD THE MACHINE

Thread the machine correctly by referring to the fig. Incorrect threading may cause skip stitching, thread breakage and uneven stitch formation. When threading the looper, tilt the looper holder toward the front of the machine using the looper drawing bar.

To tilt the looper toward the front

1. Bring needle bar A to the top of its stroke.
2. Pay out the needle thread from the spool by pressing a finger down on needle threads B.
3. Pull looper drawing bar knob C out to the left so that the looper holder is tilted toward the front of the machine.
4. After the machine is threaded, replace the looper by pressing looper holder D into the machine until it clicks.

Note:

The looper pops out of the machine as soon as knob C is pulled, so do not bring your fingers close to the looper.

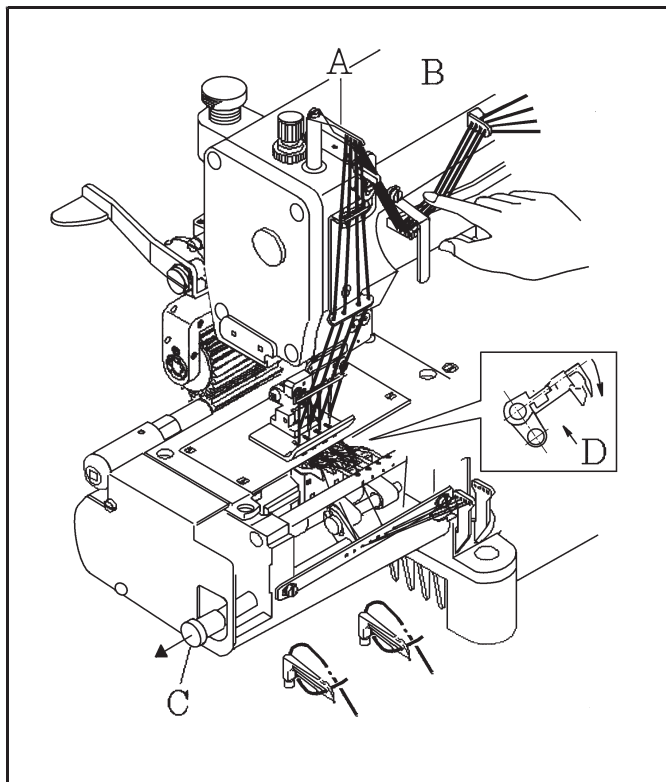

Threading diagram for 321 -4

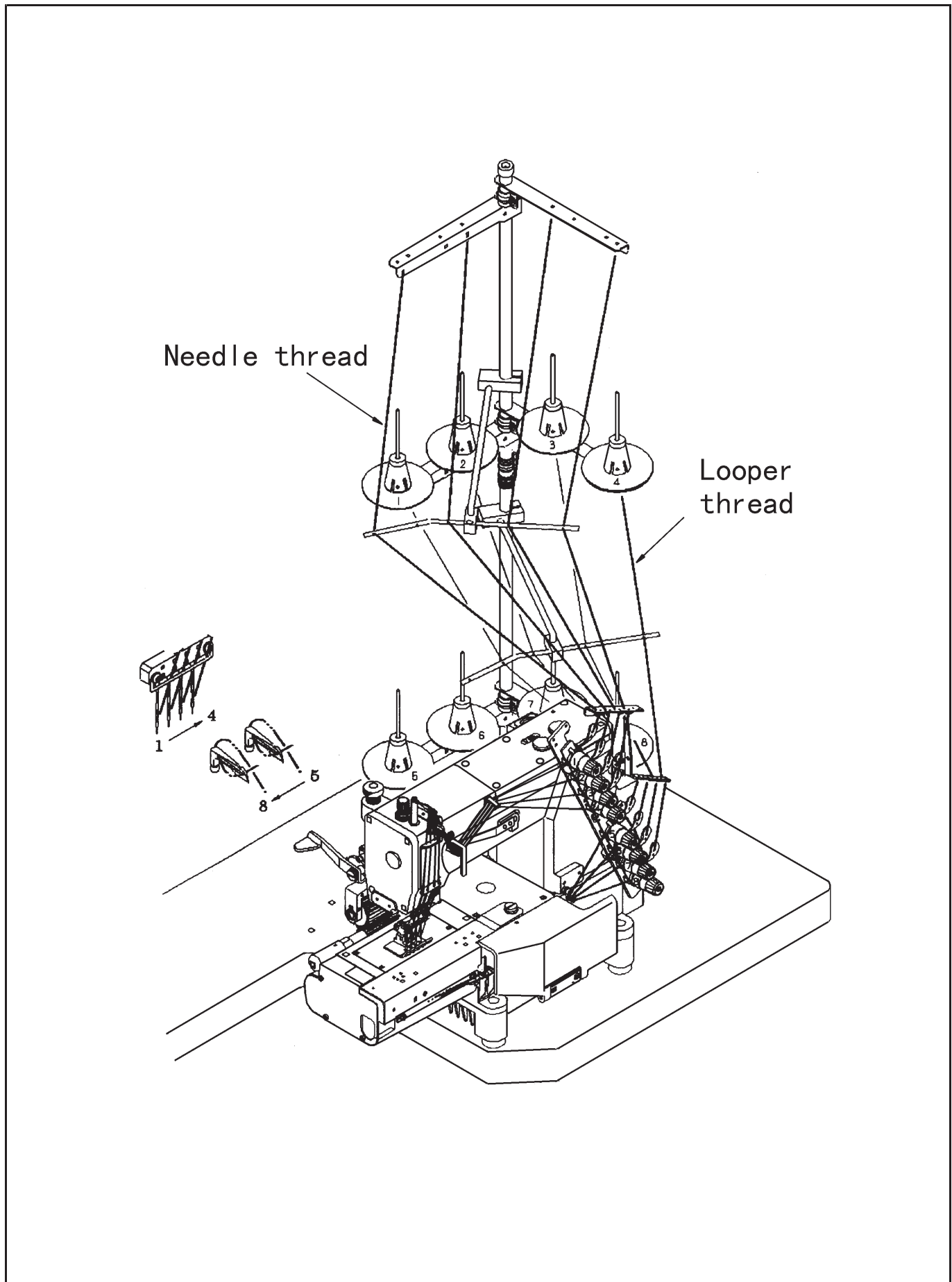

### 3. MACHINE SPEED

#### 3 – 1 MACHINE SPEED AND DIRECTION IN WHICH THE MACHINE PULLEY RUNS

Refer to the table below for max. and standard speeds of the series.

To extend machine life, run the machine approximately 15 – 20% below the max. . speed for the first 200 hours of operation (approx. 1 month).

Then run the machine at the standard speed.

The machine pulley turns clockwise as seen from the end of the machine pulley.

Model	Max speed	Standard speed
321 – 4	4000	3500
321 – 12	3500	3000

#### 3 – 2 MOTOR AND BELT

Motor: 3 – phase, 2 – pole, 400W clutch motor

Belt: M type V belt

Select the proper motor pulley according to the machine speed (refer to the motor pulley outer diameter on the table below).

Motor pulley outer diametermm	Machine speed SPM	
	50Hz	60Hz
60	2450	2950
70	2850	3450
80	3300	3900
90	3700	4400
100	4100	(4900)
110	4500	(5400)

Adjust the position of the motor by pressing the finger onto the middle of the belt so that 1 – 2cm deflection can be achieved

(see the illustration on the right).

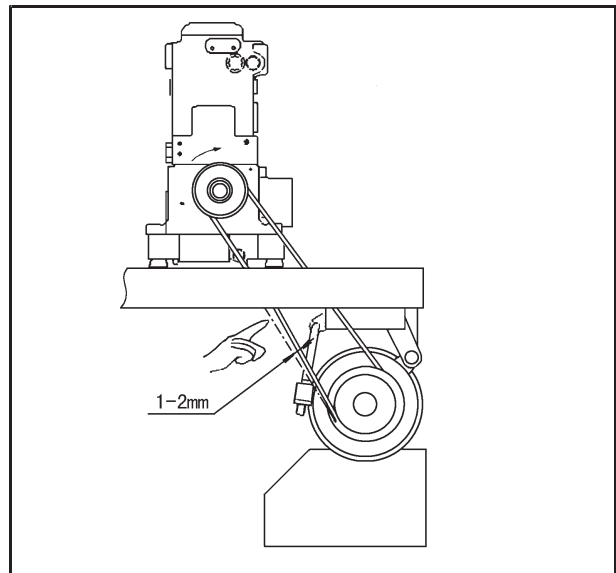

### 4. LUBRICATION

#### 4 – 1 OIL

Use 18# industrial sewing machine oil

## 4 – 2 TO FILL THE MACHINE WITH OIL

Remove rubber plug A from the oil hole. Fill the machine with oil until the oil level is at the top line (see H in the illustration) on oil gauge C. After the first lubrication, add oil so that the oil level will be between H and L. After filling the machine with oil, run the machine to check the oil is splashing onto oil pot A.

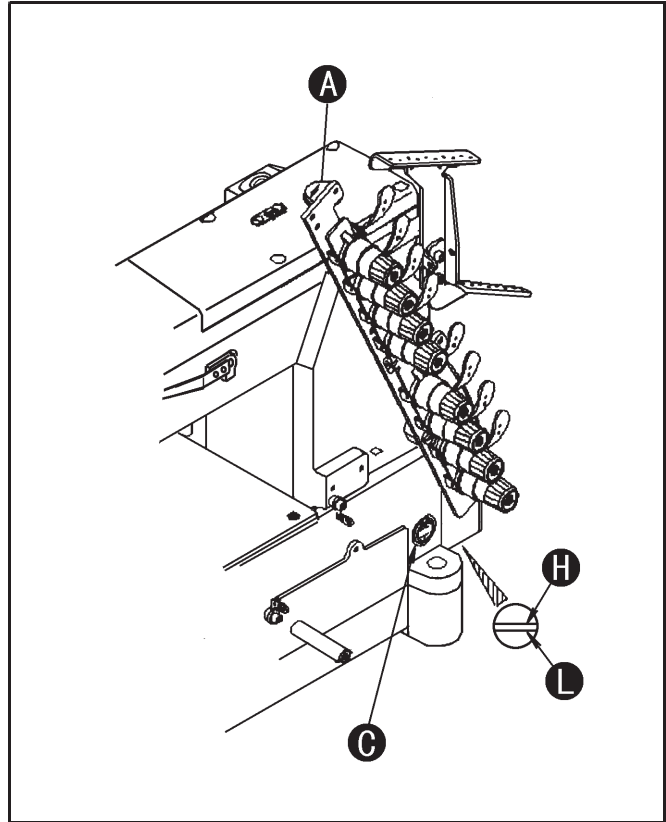

## 4 – 3 REPLACING THE OIL AND THE OIL ELEMENT

To extend machine life, be sure to replace the oil after the first 250 hours of operation.

To replace the oil, follow the procedures below.

1. Remove the V belt from the motor pulley and then remove the machine from the table.
2. Remove screw D and then drain the oil.
3. After draining the oil, be sure to tighten screw D.
4. Fill the machine with oil by referring to 4 – 2 shown above.

If element E is contaminated, proper oiling may not be performed. Clean the filter element every six months. If just a little or no oil flows out from the nozzle with the proper amount of oil in the machine, check the element. To do so, remove oil filter cap F.

Replacing the element if necessary.

Note:

When the oil filter cap is removed, the oil collected on the element drips. Be careful.

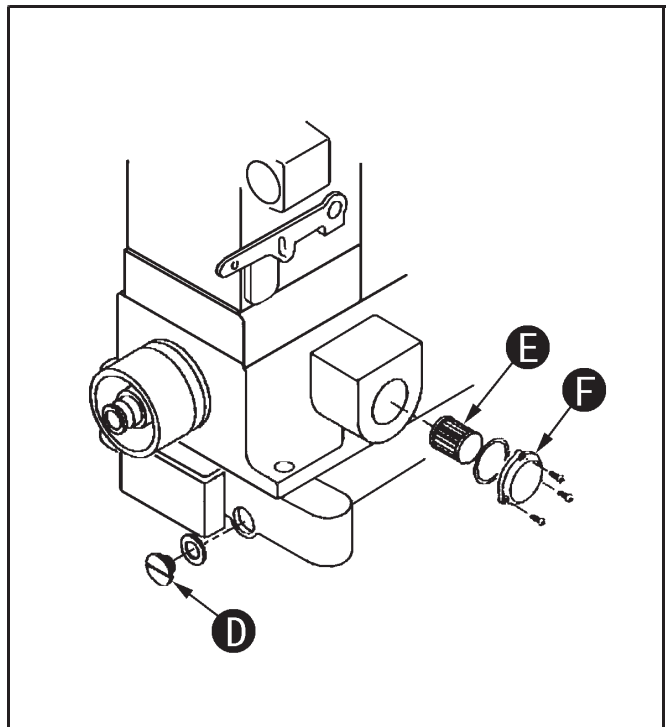



## 5. SEWING MACHINE INSTALLATION

### 5 - 1 CUTTING THE MACHINE TABLE

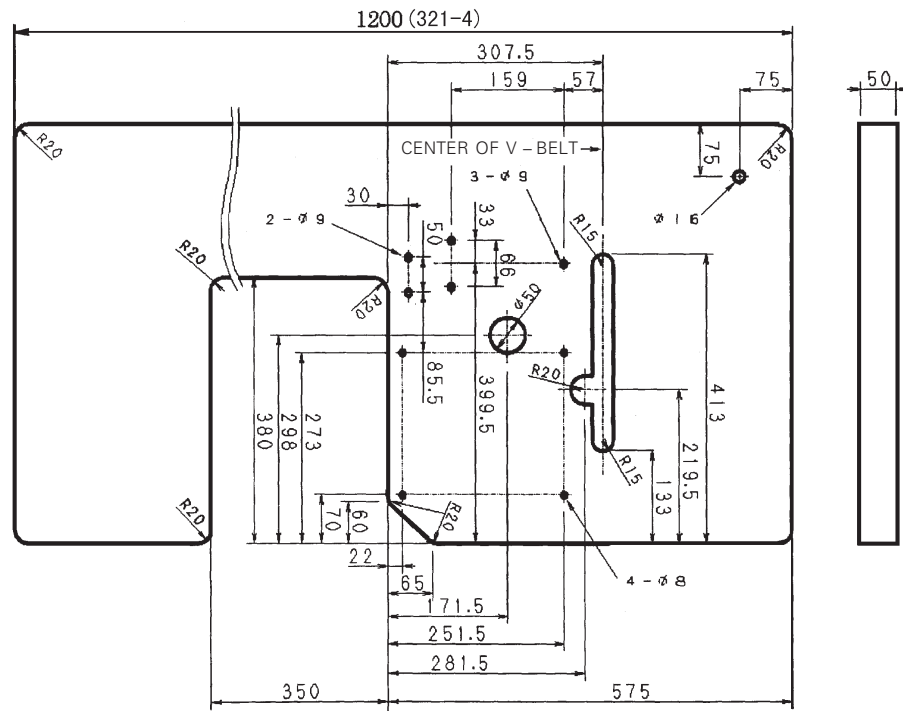

### 5 - 2 HOW TO INSTALL THE MACHINE

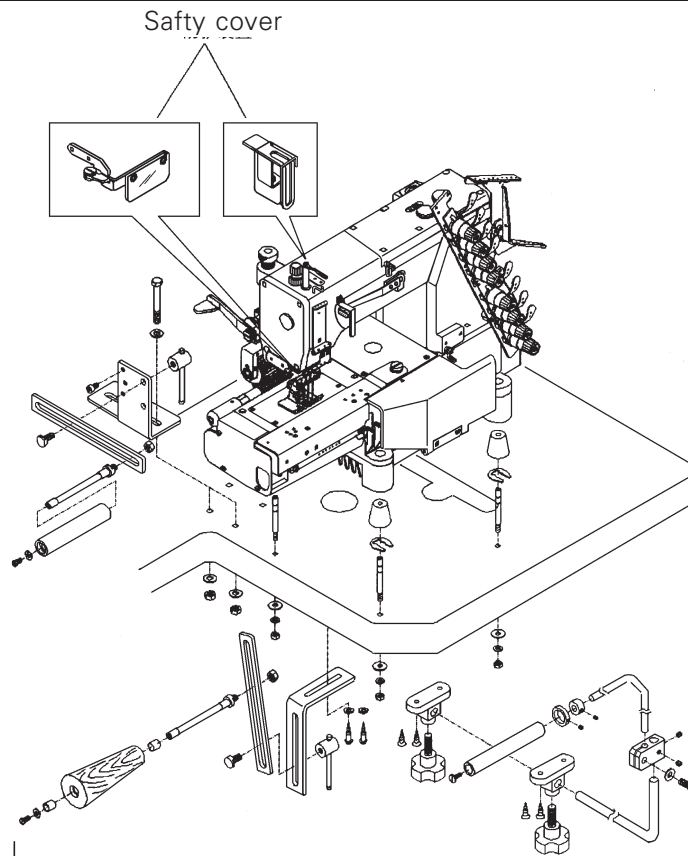

## 6. TIMING OF THE LOOPER TO THE NEEDLE

### 6 - 1 POSITIONING THE LOOPER AND LOOPER ROCKER

Insert the looper into the looper holder until bottom A of the looper touches to looper rocker B. Then tighten screw C. Then adjust screw D.

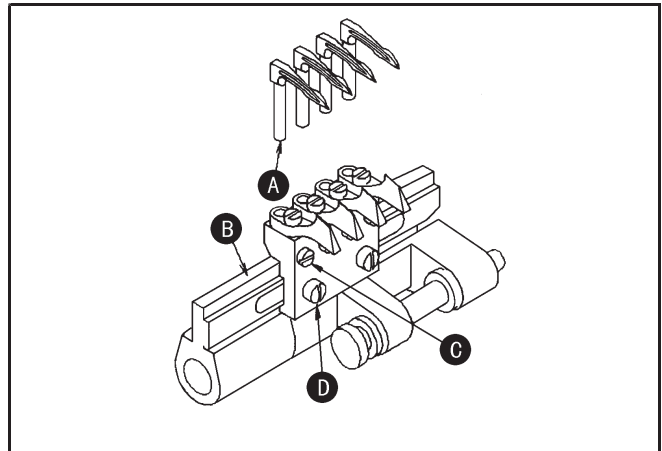

Install the looper of the machine at a  $2^\circ$  angle. Difference in level within 15 mm is approximately 0.5 mm. The clearance between the looper and the needle when the point of the looper passes the scarf on the needle should be 0 - 0.1 mm.

Adjusting is made by loosening screw D and moving the looper rocker to the left or right as required.

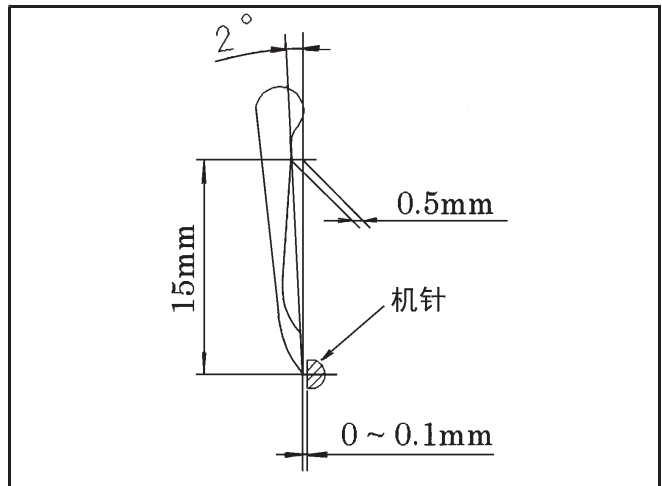

### 6 - 2 LOOPER LEFT - TO - RIGHT MOVEMENT

The timing of the looper to the needle is as follows.

When the point of the looper, moving to the right, has reached the center of the needle, the point of the looper should be 1.5mm above the top of the needle's eye. When the point of the looper, moving to the left, has reached the center of the needle, the point of the looper should be 2.3mm above the top of the needle's eye.

To make this adjustment, remove the top cover first. Loosen screw D. Then move eccentric A.

For standards, marks C is turned upward when the needle is at the top of its stroke (at the same position as eccentric B).

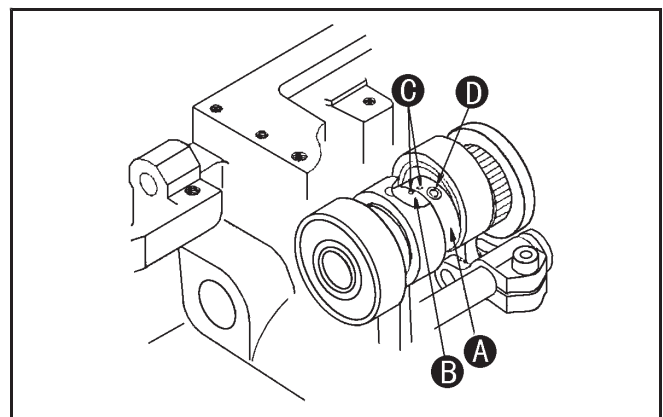
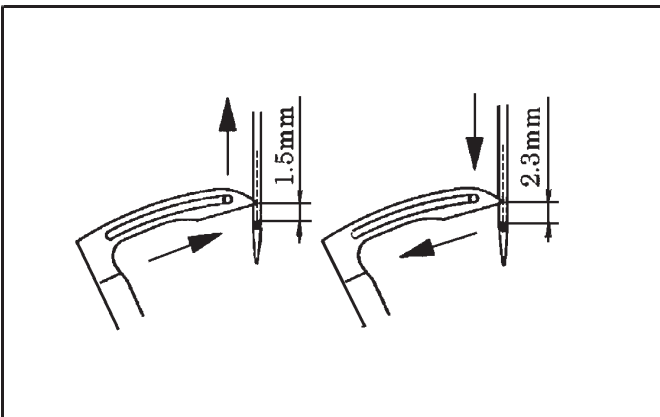

## 6 - 3 LOOPER SETTING DISTANCE

When the needle bar is at the bottom of its stroke, there should be a distance of 3 mm from the point of the looper to the center of the needle bar.

Adjustment is made by removing the top cover and loosening screw B for lever A.

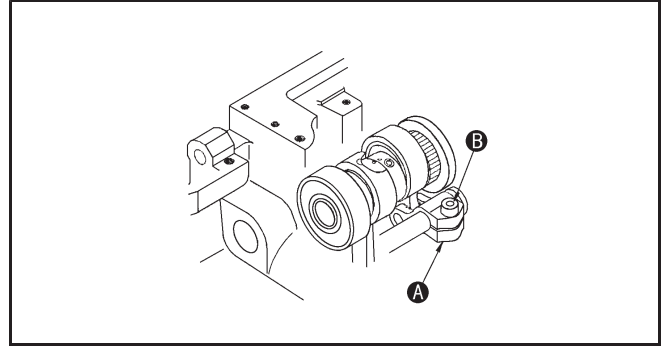
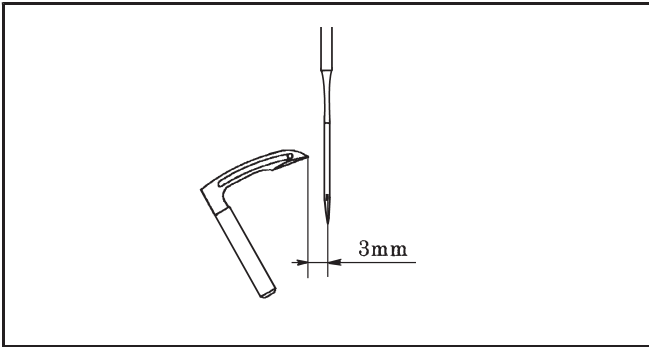

## 6 - 4 NEEDLE HEIGHT

When the needle bar is at the top of its stroke, remove plug A on the head plate, loosen needle bar clamp B with a hex wrench and then move the needle bar up or down.

<Standard needle height (distance D) >

Stroke	Standard model
34.5mm	14.5 - 14.9mm

Note:

Do not loosen the screw on needle bar guide C. If this screw is loosened, make sure each needle drops into the center of the needle drop hole and then retighten the screw.

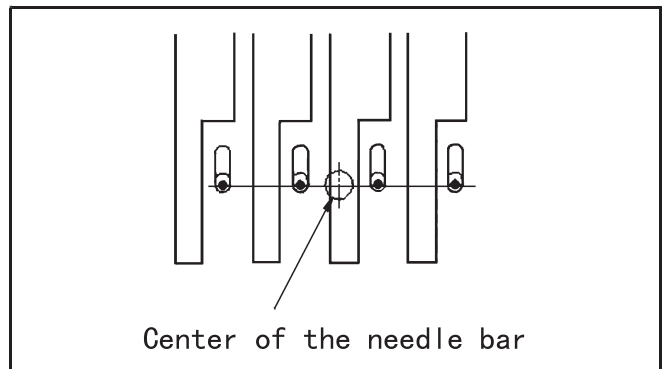
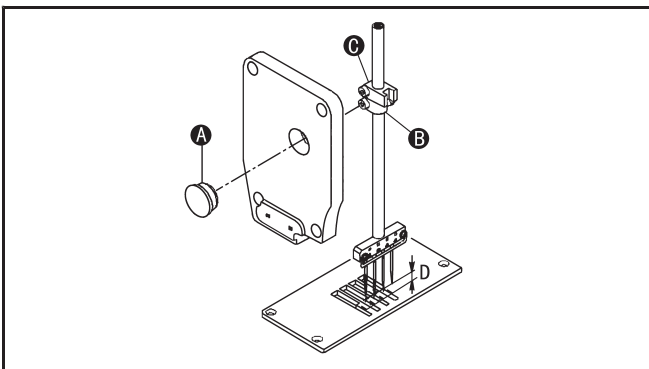

## 7. TIMING OF THE RETAINER LOOPER

### 7 - 1 INSTALLING THE RETAINER LOOPER

Install retainer looper A with its flat surface turned upward. There should be a clearance of 0.6 - 0.7 mm between the needle and the point of the retainer looper. After this adjustment, tighten screw B.

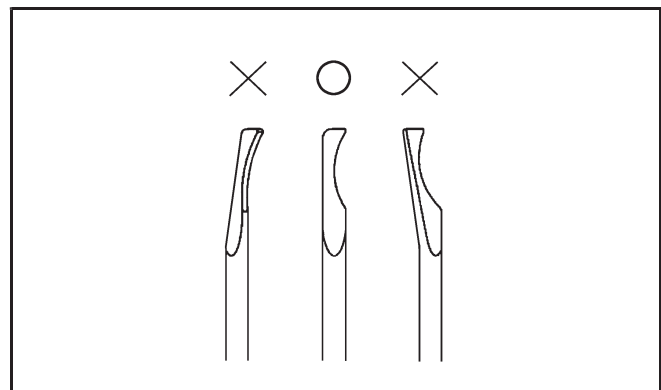
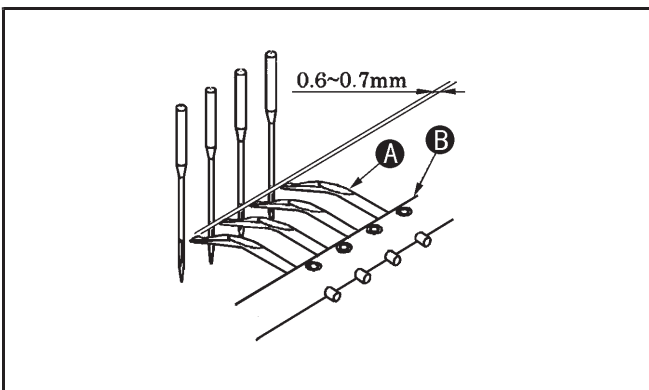

## 7 – 2 TIMING OF THE RETAINER LOOPER TO THE NEEDLE

When the point of the needle, descending from the top to the bottom of its stroke and entering the triangle formed by the looper thread, has reached approximately 4.5 mm below the point of the looper, the retainer looper should be at the extreme right end of its travel.

When the looper's eye is close to the point of the retainer looper while the needle bar is ascending to the top of its stroke, there should be a clearance of 0.3 mm between the right side of the retainer looper and that of the looper. When the needle bar is at the top of its stroke, there should be a clearance of 0 mm between the right side of the retainer looper and that of the top surface (heel) of the looper blade.

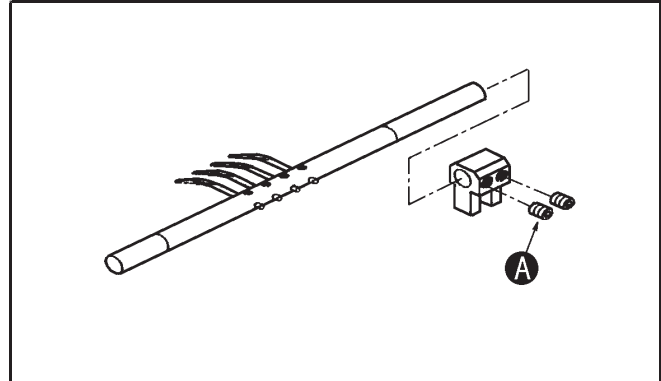
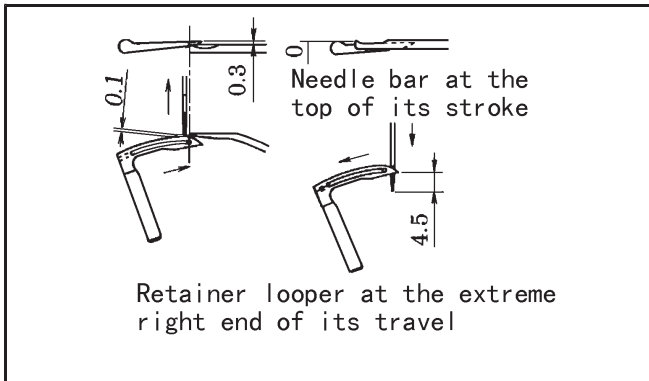

## 8. ADJUSTING THE NEEDLE GUARD

### 8 – 1 POSITION OF THE NEEDLE GUARD

When the right side of the needle is the closest to needle guard A, there should be clearance of 0 – 0.1mm between them. Adjustment is made by loosen screw B.

Note:

For a standard type of needle guard, loosen the looper set screw after positioning the looper rocker, adjust the needle guard and then tighten screw B.

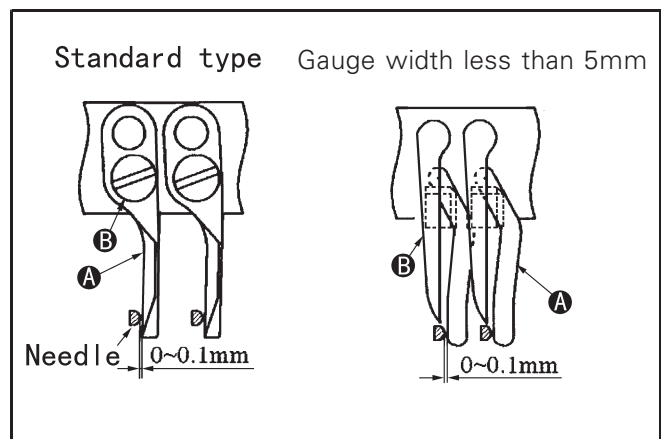

## 9. ADJUSTING THE FEED DOG AND STITCH LENGTH

### 9 – 1 FEED DOG HEIGHT AND TILT

When the needle bar is at the top of its stroke, the feed dog teeth should be 1 – 1.2 mm above the top surface of the needle plate. Adjustment is made by loosen screw A. Tilt adjustment is made by inserting a tool from D and adjusting screws B and C.

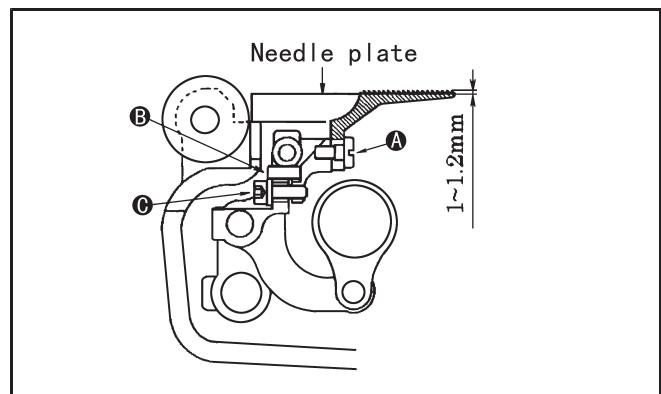

After marking this adjustment, make sure the feed dog is parallel with the top surface of the needle plate.

Note:

Before adjusting the height of the feed dog, tilt the looper holder.

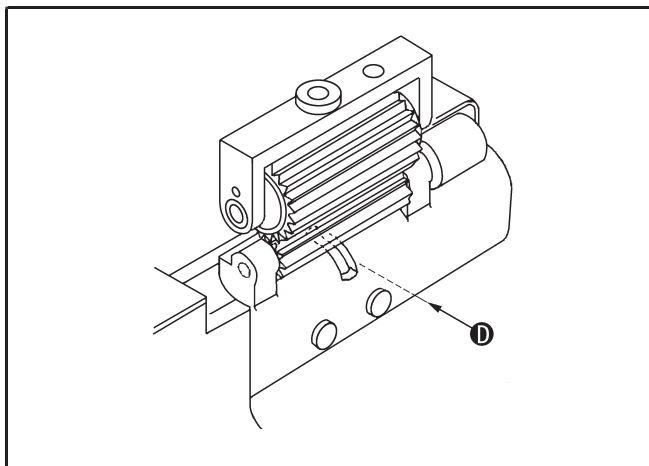

## 9 – 2 STITCH LENGTH

The stitch length can be adjusted from 2 to 5 mm with no step.

The following table shows the stitch length with the number of stitches within 1 inch (25.4 mm) and 30 mm.

Stitch length (mm)	No. of stitches	
	Within 1"	Within 30mm
2	13	15
3	8.5	10
5	5	6

To change the stitch length

1. Press push button A lightly with the left hand until the end of push button A touches an inside part and clicks.
2. With push button A depressed, turn the hand wheel with the right hand until the push button goes further into the depth.
3. Press the push button strongly again. Then turn the machine pulley to select the stitch length as required.
4. Align the desired stitch length with alignment mark B. then release the left hand.

Note:

Before changing the stitch length, be sure to turn off the motor.

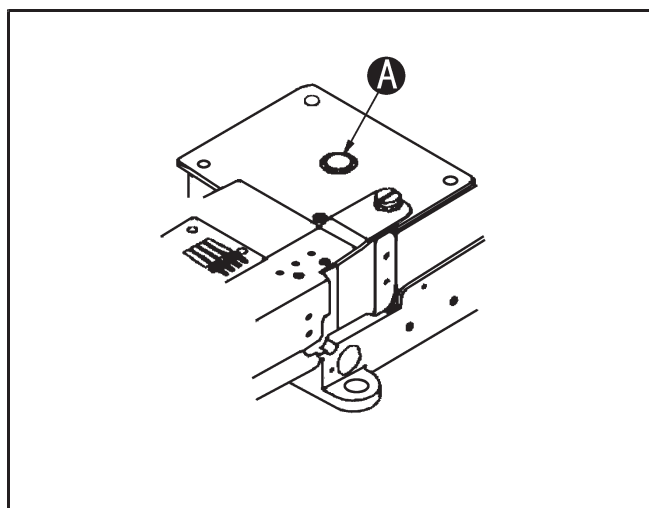

## 10. ADJUSTING THE PRESSER FOOT

### 10 – 1 PRESSER FOOT PRESSURE

The presser foot pressure should be as light as possible, yet be sufficient to feed the fabric and produce uniform stitches. To increase the presser foot pressure, turn the adjusting knob clockwise (see the illustration).

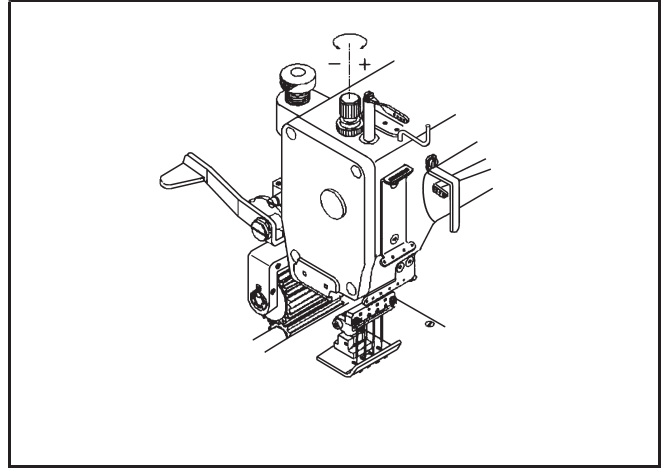

### 10 – 2 POSITION OF THE PRESSER FOOT AND FOOT LIFT

Fit the presser foot properly onto the presser bar.

Make sure the needle is centered left to right in the needle drop hole on the presser foot when the needle is descending. Adjustment is made by loosening screw A. There should be a clearance of 0.5 mm on both sides as shown in the illustration.

Adjustment is made by loosening nuts B.

Foot lift position stopper C with the presser foot approximately 10 mm above the top surface of the needle plate and then tighten nut D.

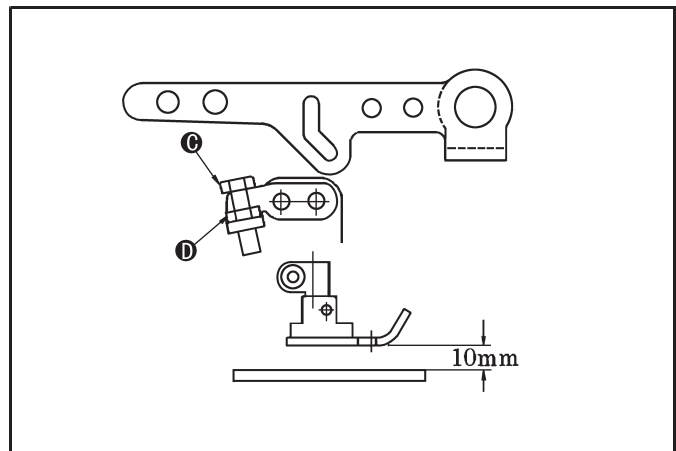
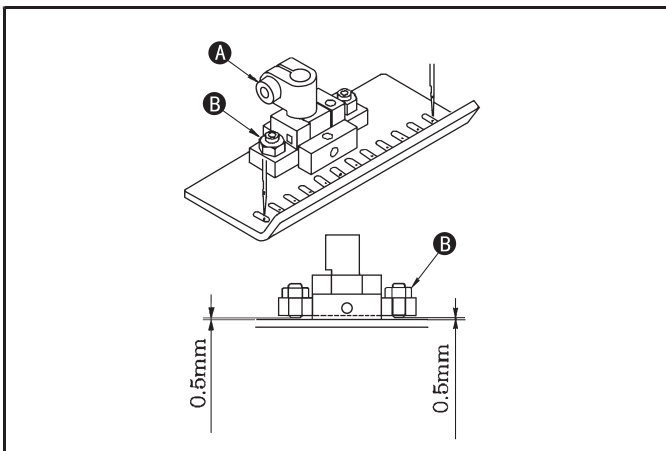

## 11. ADJUSTING THE REAR PULLEY DEVICE

### 11 - 1 MANUAL LEVER AND POSITION OF THE STOPPER

To position or remove the fabric, raise manual lever A. with the manual lever lowered, hold stopper B so that the clearance between the upper and lower pullers is 0.5 mm. Then tighten nut C.

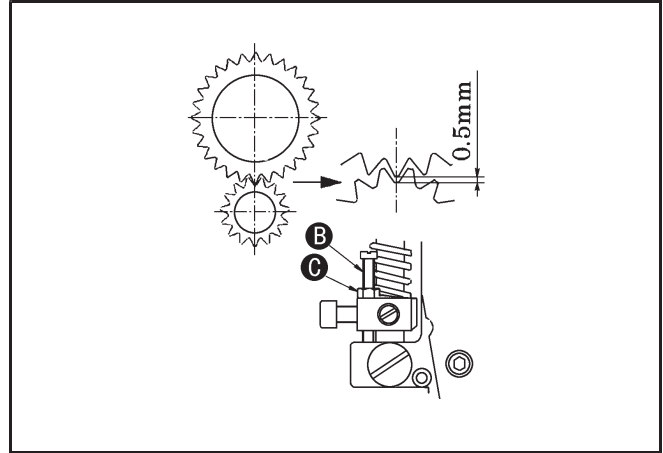

### 11 - 2 TO ADJUST THE PULLER PRESSURE

The puller pressure should be as light as possible, yet be sufficient to feed the fabric smoothly.

To increase the pressure, turn adjusting knob D clockwise. to decrease the pressure, turn adjusting knob D counterclockwise.

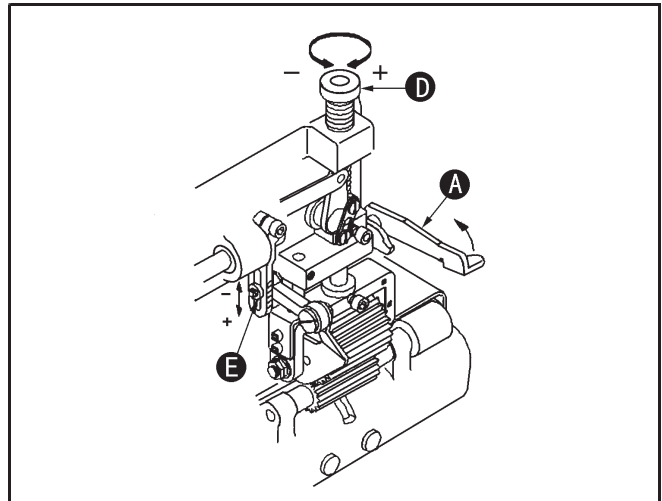

### 11 - 3 TO ADJUST THE FEEDING AMOUNT OF THE REAR PULLER

Adjust the feeding amount of the rear puller according to that of the feed dog.

To increase the amount, loosen nut E and move it down.

To decrease the amount, loosen nut E and move it up.

If the feeding amount is too large or small, remove rubber plug F, loosen screw G with a hex wrench and move screw G to the left or right.

To increase the amount, move screw G to the right.

To decrease the amount, move screw G to the left.

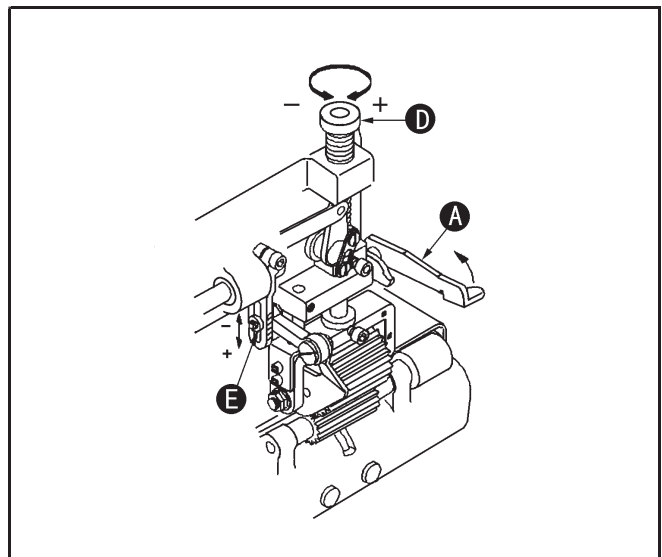

## 12. ADJUSTING THE STITCH FORMATION

### 12 – 1 THREAD TENSION ADJUSTMENT

Thread tension varies according to sewing conditions such as the fabric, thread and stitch length to be used.

Tension on the needle thread can be adjusted with nut A. Tension on the looper thread can be adjusted with nuts B. To increase the tension, turn the nuts clockwise.

Note:

The tension should be as light as possible, yet be sufficient to produce uniform stitches.

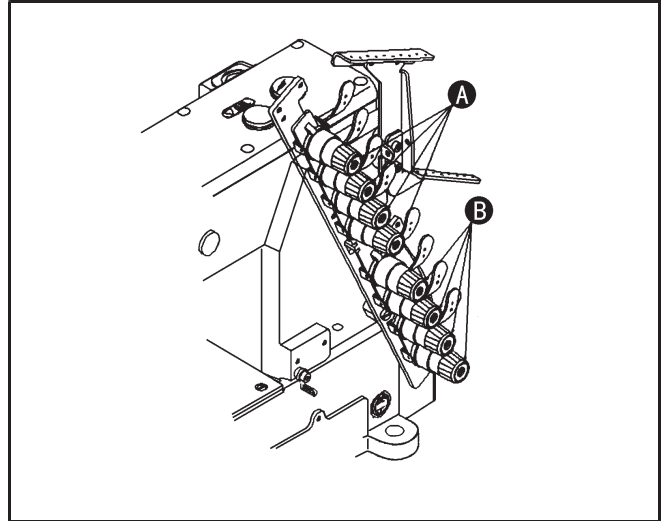

### 12 – 2 POSITION OF THE NEEDLE THREAD EYELET

Position needle thread eyelet C so that the distance from the center of the screw to the eyes of C is approximately 40 mm.

Note:

Adjust the needle thread eyelet according to the thread to be used. To tighten the needle thread, raise the needle thread eyelet.

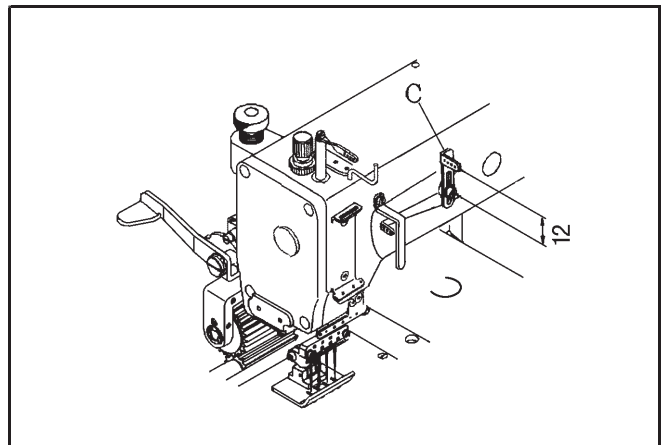

### 12 – 3 TO ADJUST THE NEEDLE THREAD GUARD

With the needle bar at the bottom of its stroke, the centers of the eyes on needle bar eyelet B should be level and parallel with the top surface of needle thread guard A.

Note:

Raising needle thread guard A increases the size of the needle thread loop.

Lowering needle thread guard A decreases the size of the needle thread loop.

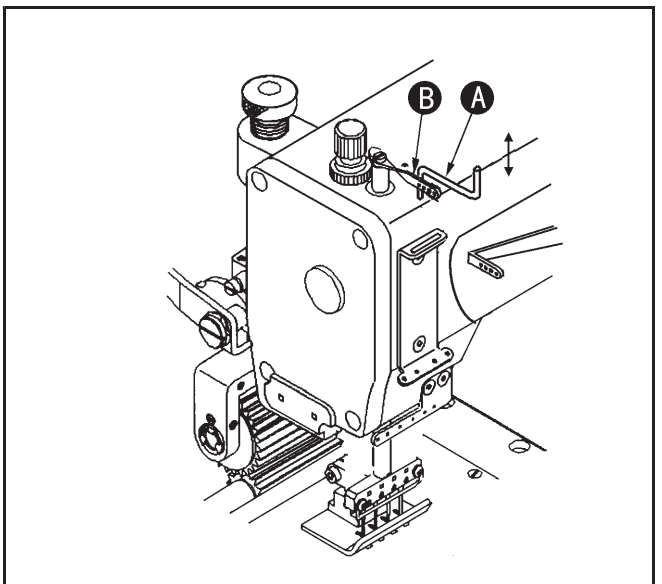



## 12 – 4 POSITION AND TIMING OF THE LOOPER THREAD TAKE – UP EYELET

When the point of the needle is level with the top surface of the looper while the needle bar is descending from the top to bottom of its stroke on the back side of the looper, the looper thread take – up bar should start ascending.

Adjusting is made by loosening the screw and aligning the mark on the eccentric with that on the main shaft. Then the looper thread take – up bar is at the bottom of its stroke, adjust distance A from the eyes on the thread eyelet to the looper thread take – up bar by referring to the table below.

Thread type	Distance A
polyester	8mm
Spun	10mm
Woolly	15mm

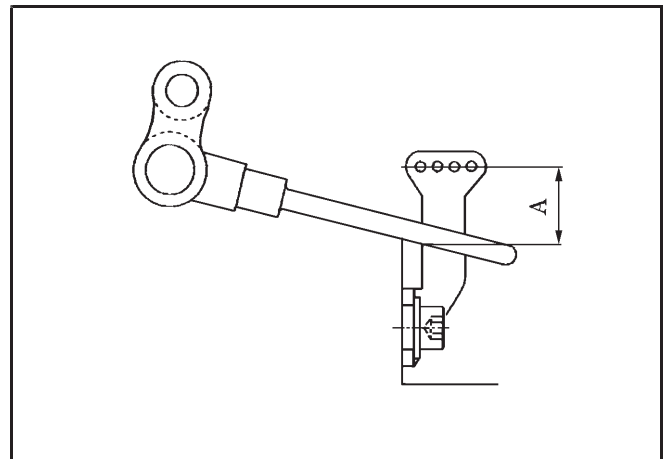
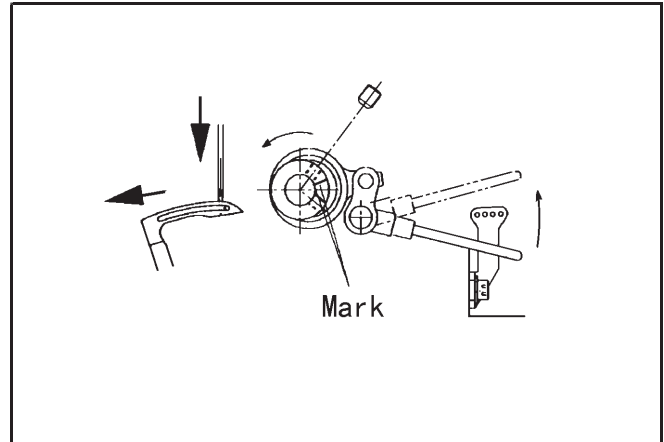

## 13. CLEANING THE MACHINE

At the end of each day, remove the presser foot and the needle plate and then clean the slots of the needle plate and the area around the feed dogs.

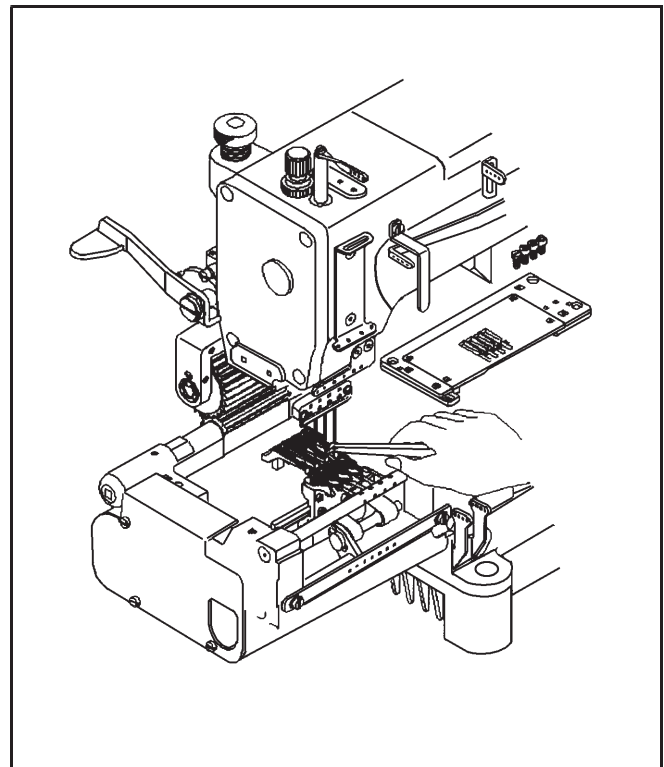

# 1. FRAME ASSEMBLY (1)

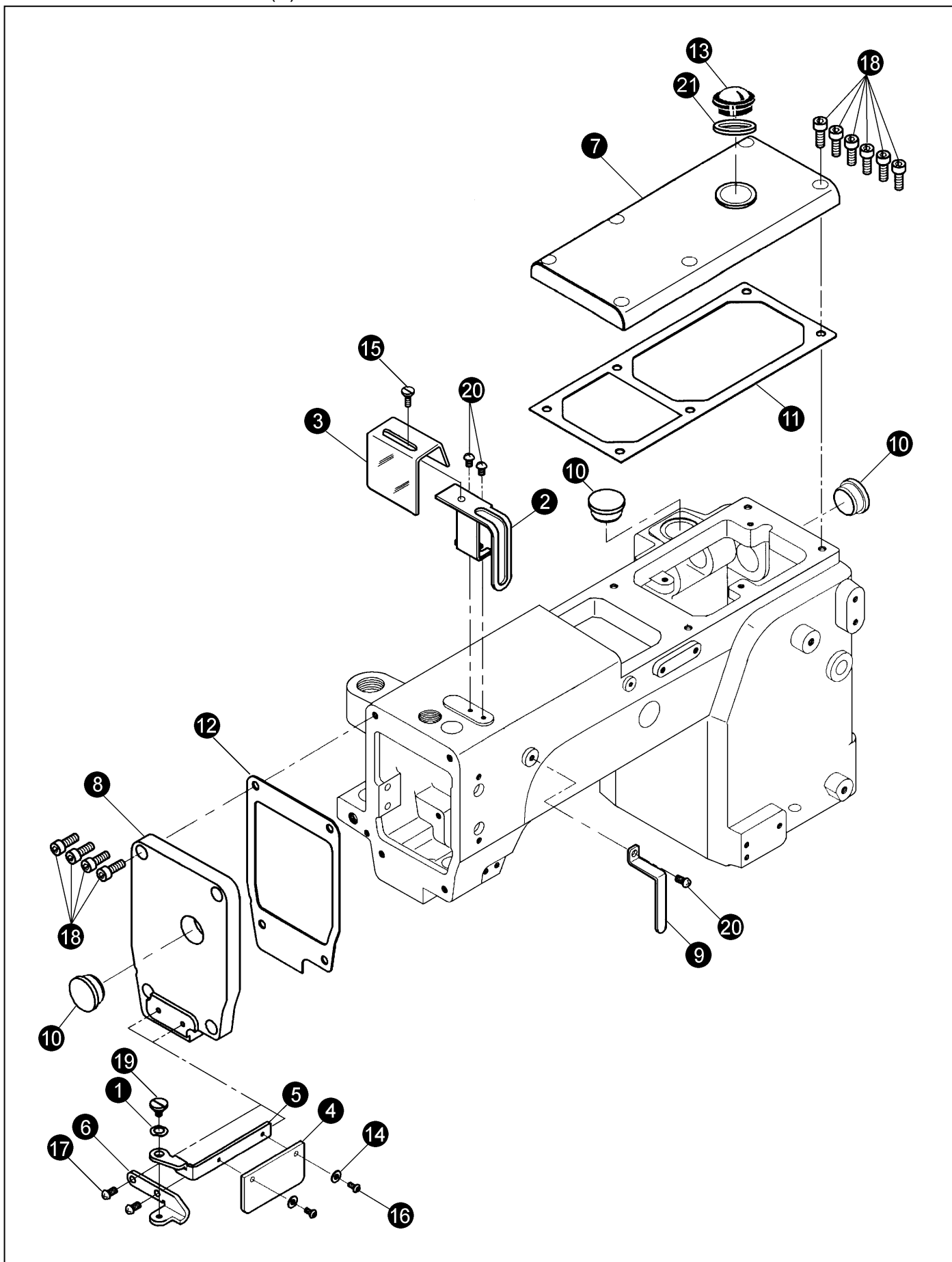

## 1. FRAME ASSEMBLY (1)

No.	Ref. No.	Description	Qt.
1	S150603003	Washer GB860 - 87 6	1
2	197120001	Needle bar guard	1
3	197120002	Needle bar cover	1
4	197130001	Eye guard	1
5	197130002	Eye guard support	1
6	197130003	Eye guard bracket	1
7	197140001	Top cover	1
8	197100001	Face plate	1
9	197100003	Thread take - up lever guard	1
10	197100004	Rubber plug	3
11	197100005	Gasket	1
12	197100002	Gasket	1
13	043120002	Oil sight window	1
14	008230003	Washer BQ10008	2
15	197120003	Screw	1
16	S150202010	Screw GB66 - 76 M4 x 6	2
17	S150299035	Screw M4 x 8	2
18	S150299002	Screw M5 x 14	10
19	197130004	Screw	1
20	S150299035	Screw M4 x 8	1
21	S150651011	O - type ring 25.8 x 1.8	1

## 2. FRAME ASSEMBLY (2)

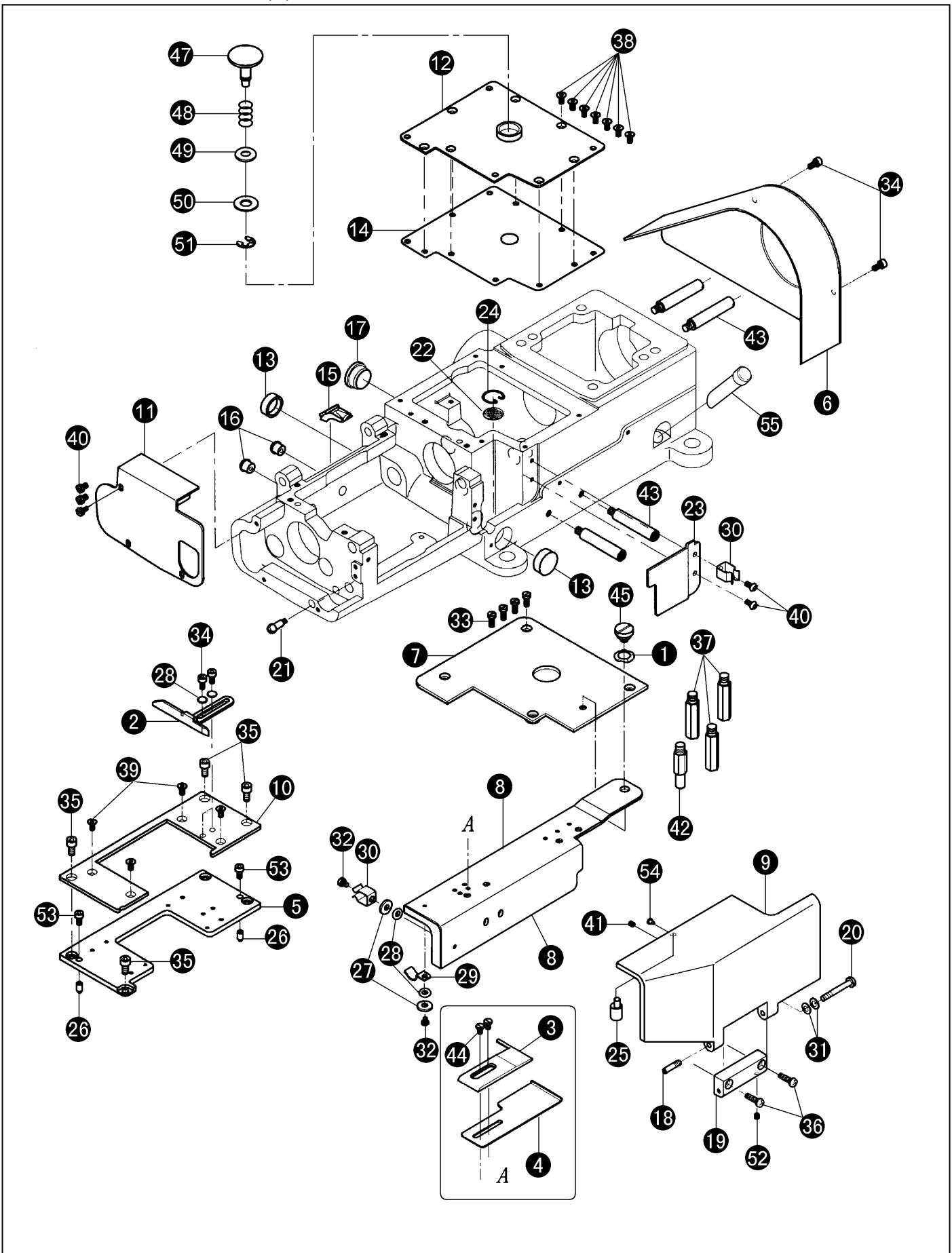

## 2. FRAME ASSEMBLY (2)

No.	Ref. No.	Description	Qt.
1	197150002	Washer12	1
2	197100006	Material guide	1
3	197100007	Tape guide, left	1
4	197100008	Tape guide, right	1
5	197100009	Needle plate support bracket	1
6	197F01001	Pulley cover	1
7	197151000	Upper cover	1
8	197152001	Front plate cover	1
9	197160001	Front cover	1
10	197100011	Cover	1
11	197100012	Left cover	1
12	197171000	Upper cover	1
13	197100013	Rubber plug	2
14	197100014	Gasket	1
15	197100015	Rubber plug	1
16	197100025	Rubber plug	2
17	197100004	Rubber plug	1
18	197160003	Screw	1
19	110150002	Hinge	1
20	197160002	Screw	1
21	197100017	Pin	1
22	110300005	Oil filter screen	1
23	197100018	Oil fence	1
24	110300006	Clamp	1
25	197160004	Pin	1
26	182100045	Pin	2
27	110200005	Washer	2
28	008230003	Washer 4	4
29	197152002	Spring	1
30	197100016	Spring	2
31	S150603002	Washer 5	2
32	S150202009	Screw M4 x 5	2
33	S150299031	Screw M4 x 10	4
34	S150299005	Screw	2
35	S150299003	Screw M5 x 10	4
36	S150216013	Screw M4 x 12	2
37	197100020	Support pole	3
38	S150203002	Screw M4 x 8	7
39	S150203002	Screw	4
40	S150299035	Screw M4 x 8	5
41	S150299027	Screw M4 x 4	1
42	197100021	Support pole (S)	1
43	197100022	Screw	4
44	S150202010	Screw M4 x 6	2
45	197150001	Screw	1
46	197900012	Oil sight gauge	1
47	197170001	Push button	1
48	197170002	Spring	1
49	S150656012	O - type ring 5 x 1.8G	1
50	110440009	Washer	1
51	S150620004	C - type ring 4	1
52	S150299008	Screw M3 x 3	1
53	S150299005	Screw M4 x 10	2
54	110150005	Rubber plug	1

### 3. THREAD TENSION MECHANISM

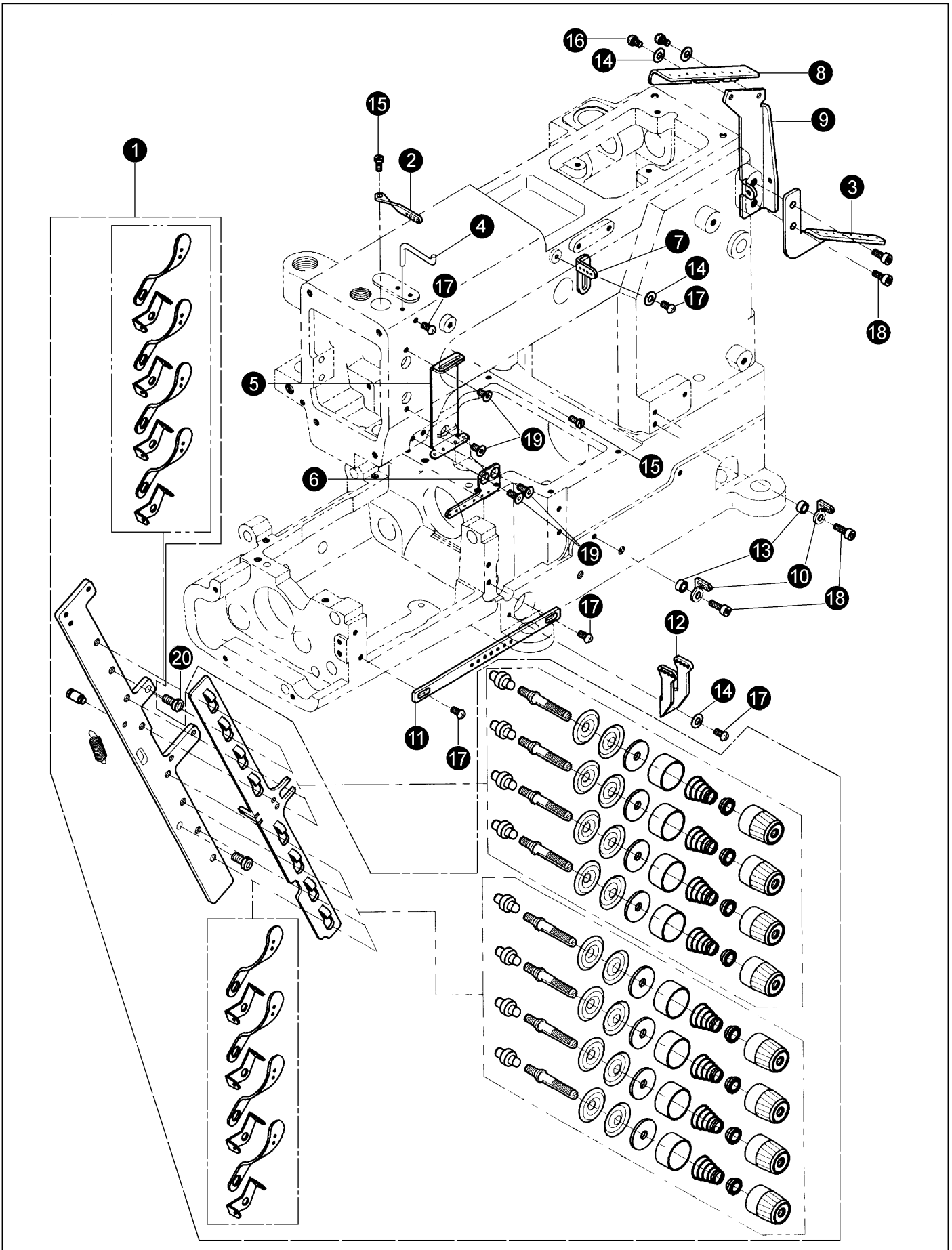

### 3. THREAD TENSION MECHANISM

No.	Ref. No.	Description	Qt.
1	197210000	Tension post support	1
2	197200001	Thread eyelet	1
3	197200002	Looper thread eyelet	1
4	110200026	Thread take - up eyelet	1
5	197200004	Thread eyelet	1
6	197200005	Thread eyelet	1
7	197200006	Thread eyelet	1
8	197220001	Thread guide	1
9	197220002	Thread guide support	1
10	197200007	Thread eyelet	2
11	197200009	Thread eyelet	1
12	197200010	Tension disc separator	1
13	197200008	Collar	2
14	008230003	Washer 4	4
15	197480012	Screw SM9/64" ( 3.57 ) x 40 x 7	1
16	S150216017	Screw M4 x 5	2
17	S150299035	Screw M4 x 8	5
18	S150299005	Screw M4 x 10	4
19	S150203002	Screw	4
20	S150299003	Screw M5 x 10	2

## 4. BUSHING

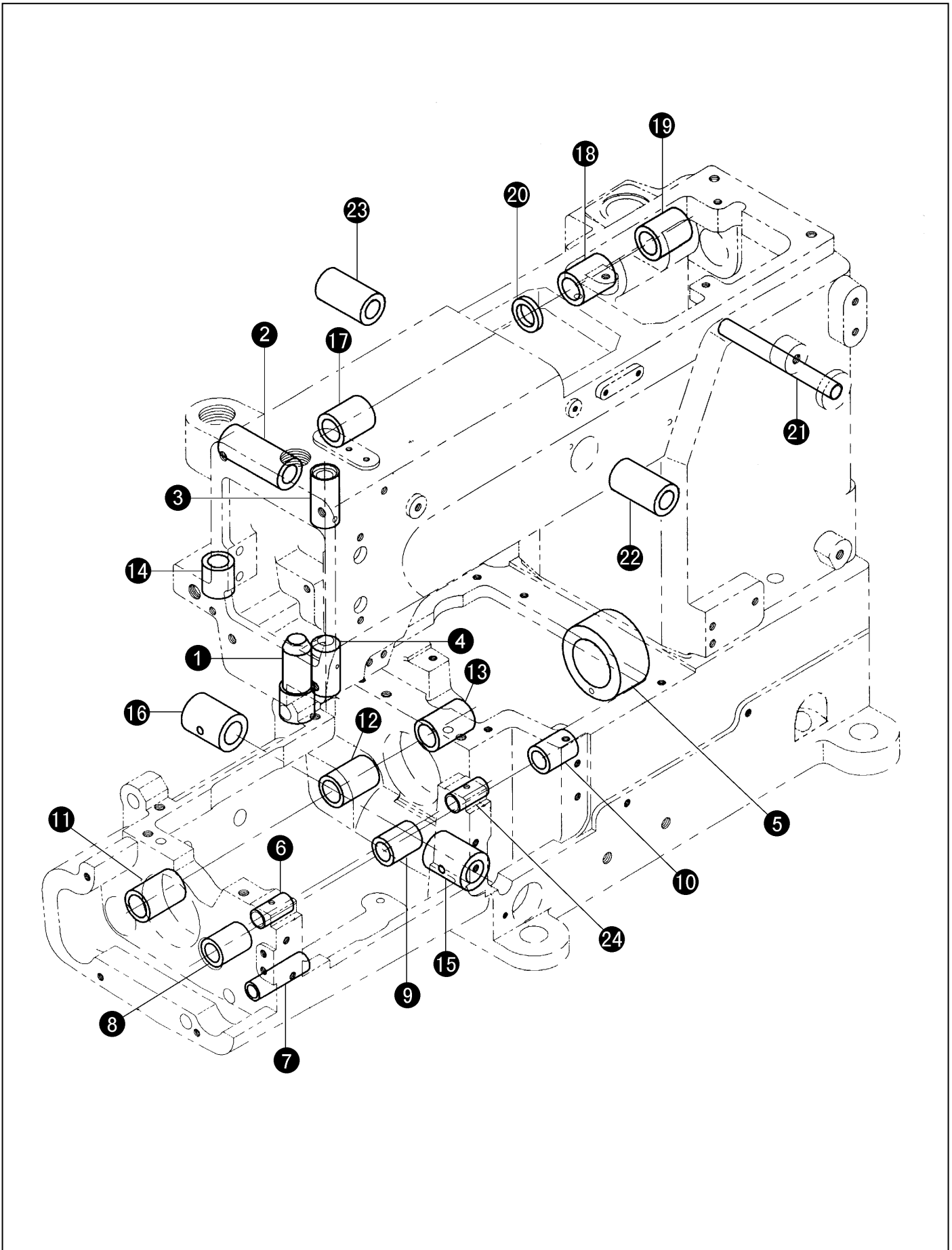



#### 4. BUSHING

No.	Ref. No.	Description	Qt.
1	110600007	Bushing	1
2	197800003	Bushing	1
3	197800001	Bushing	1
4	197800002	Bushing	1
5	197800008	Bushing	1
6	197800012	Bushing	1
7	197800009	Bushing	1
8	197800017	Bushing	1
9	197800018	Bushing	1
10	197800019	Bushing	1
11	197800014	Bushing	1
12	197800015	Bushing	1
13	197800016	Bushing	1
14	197800004	Bushing	1
15	197800010	Bushing	1
16	197800011	Bushing	1
17	197800005	Bushing	1
18	197800006	Bushing	1
19	197800007	Bushing	1
20	197800020	Oil seal	1
21	197600007	Bushing	1
22	197300007	Bushing	1
23	197300008	Bushing	1
24	197800013	Bushing	1

# 5 . NEEDLE BAR MECHANISM

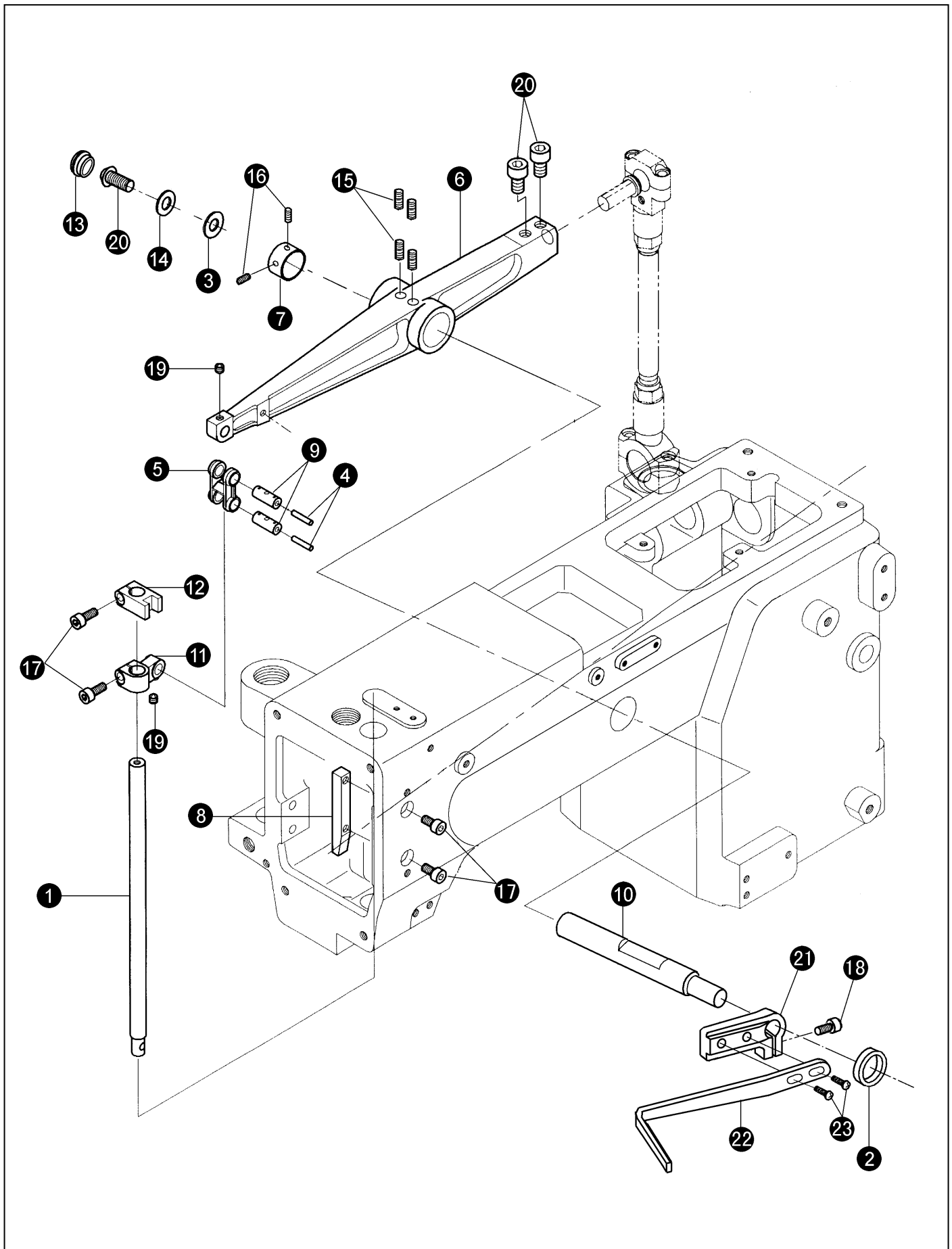

## 5 . NEEDLE BAR MECHANISM

No.	Ref. No.	Description	Qt.
1	197300001	Needle bar	1
2	110280000	Oil seal	1
3	197300005	Washer	1
4		Wool	2
5	197310002	Link	1
6	197310001	Needle lever	1
7	197300006	Collar	1
8	197300003	Needle bar guide	1
9	197310003	Pin	2
10	197300004	Needle lever stud	1
11	197310004	Needle bar clamp	1
12	197300002	Slide block	1
13	197300009	Rubber plug	1
14	S150603003	Washer GB860 - 87 6	1
15	S150299029	Screw M6 x 6	4
16	S150299028	Screw M5 x 5	2
17	S150299005	Screw M4 x 10	4
18	S150299002	Screw M5 x 14	1
19	S150299017	Screw M4 x 4	2
20	S150299006	Screw M6 x 10	3
21	197230001	Thread take - up crank	1
22	197230002	Thread take - up lever	1
23	S150299035	Screw M4 x 8	2

## 6. CRANK SHAFT MECHANISM

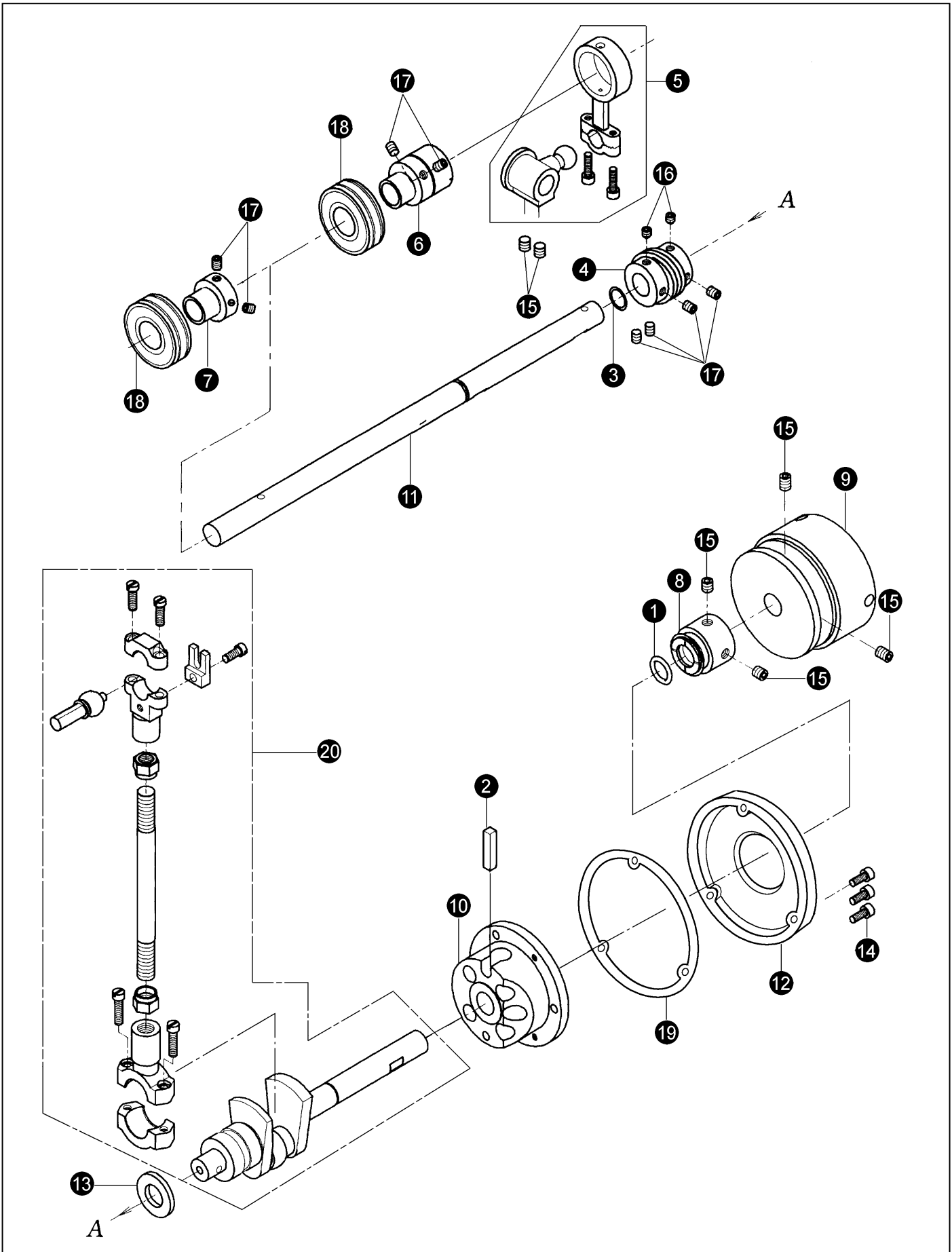

## 6. CRANK SHAFT MECHANISM

No.	Ref. No.	Description	Qt.
1	S150651031	O - type ring13.2 x 1.8G	1
2		Wick	1
3	S150651029	O - type ring 9.5 x 1.8	1
4	197450001	Worm	1
5	197410000	Connecting rod assy.	1
6	197440001	Eccentric wheel	1
7	197430001	Sleeve	1
8	197460001	Collar	1
9	197470001	Pulley	1
10	197400003	Flange	1
11	197400001	Shaft	1
12	197400002	Cover	1
13	197400005	Washer	1
14	S150299005	Screw M4 x 10	3
15	S150299029	Screw M6 x 6	6
16	S150299020	Screw M5 x 6	2
17	S150299028	Screw M5 x 5	8
18	S150801150	Bearing 6203 - 2ZN	2
19	197400004	Washer	1
20	197420000	Connecting rod assy	1

# 7. FEED MECHANISM

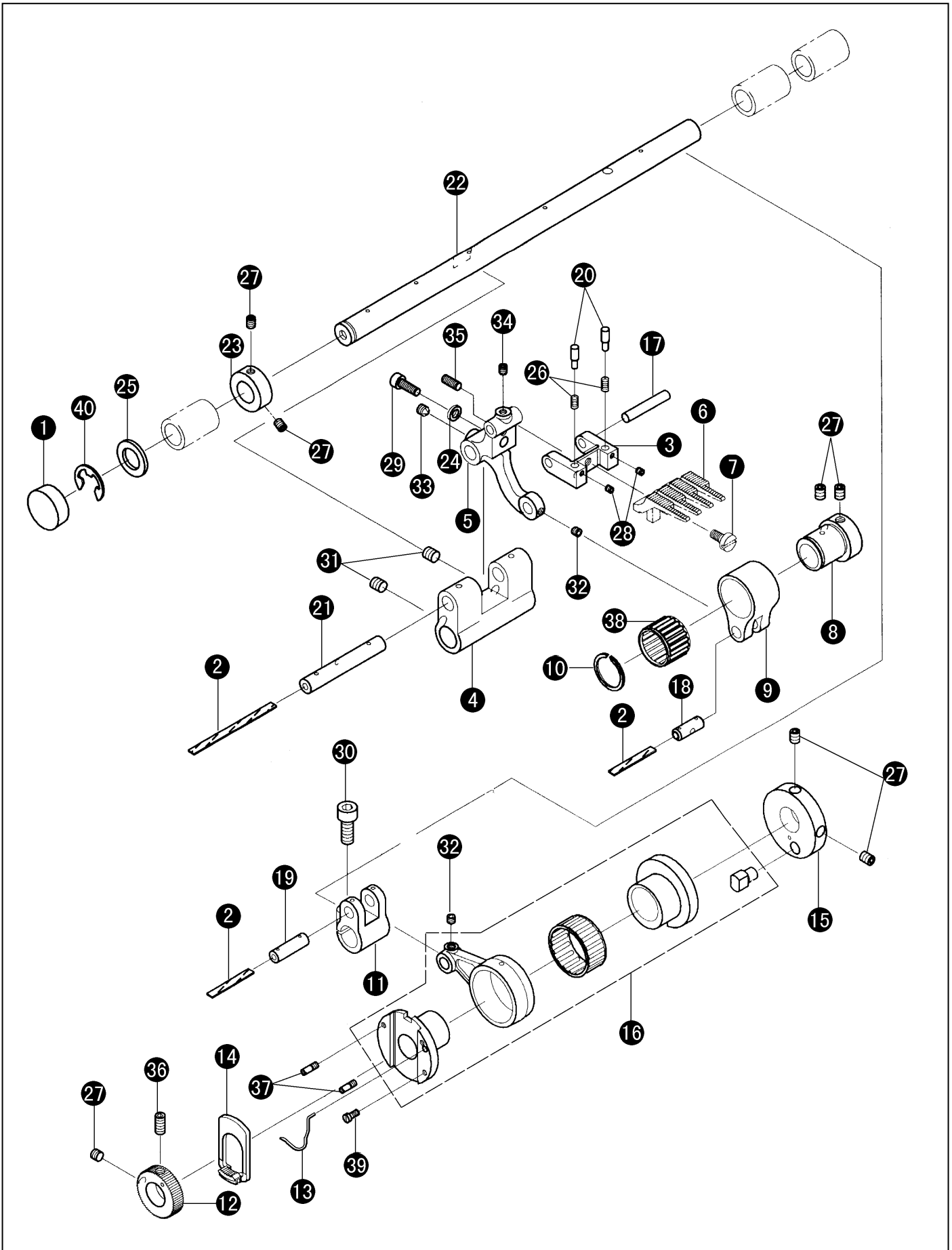

## 7. FEED MECHANISM

No.	Ref. No.	Description	Qt.
1	197100013	Rubber plug	1
2		Wool	2
3	197510002	Feed dog holder	1
4	197510001	Feed rocker	1
5	197510003	Feed bar	1
6	197510011	Feed dog	1
7	022400015	Screw SM11/64"(4.37) x 40 x 10	1
8	197510004	Eccentric	1
9	197510005	Rocker link	1
10	197510010	C - type ring	1
11	197520003	Feed crank	1
12	197520010	Sprocket wheel	1
13	197520008	Spring	1
14	197520009	Regulating plate	1
15	197520001	Eccentric collar	1
16	197521000	Needle distance adjusting assy	1
17	197510006	Feed bar shaft	1
18	008400017	Rocker link shaft	1
19	197520004	Feed link shaft	1
20	197510008	Pin	2
21	197510007	Feed link shaft	1
22	197500002	Feed shaft	1
23	197500003	Collar	1
24	008230003	Washer 4	1
25	197500004	Washer	1
26	197510009	Spring	2
27	S150299028	Screw M5 x 5	7
28	S150299008	Screw M3 x 3	2
29	S150299005	Screw M4 x 10	1
30	S150299024	Screw M6 x 14	1
31	S150299029	Screw M6 x 6	2
32	S150299017	Screw M4 x 4	2
33	S150299020	Screw M5 x 6	1
34	S150299027	Screw M4 x 4	1
35	S150212019	Screw M4 x 10	1
36	110460013	Screw	1
37	110460011	Screw	2
38	S150801025	Needle bearing assy	1
39	S150299030	Screw GB818 - 85 M3×6	1
40	S150620003	E - type ring 9	1

# 8. LOOPER MECHANISM

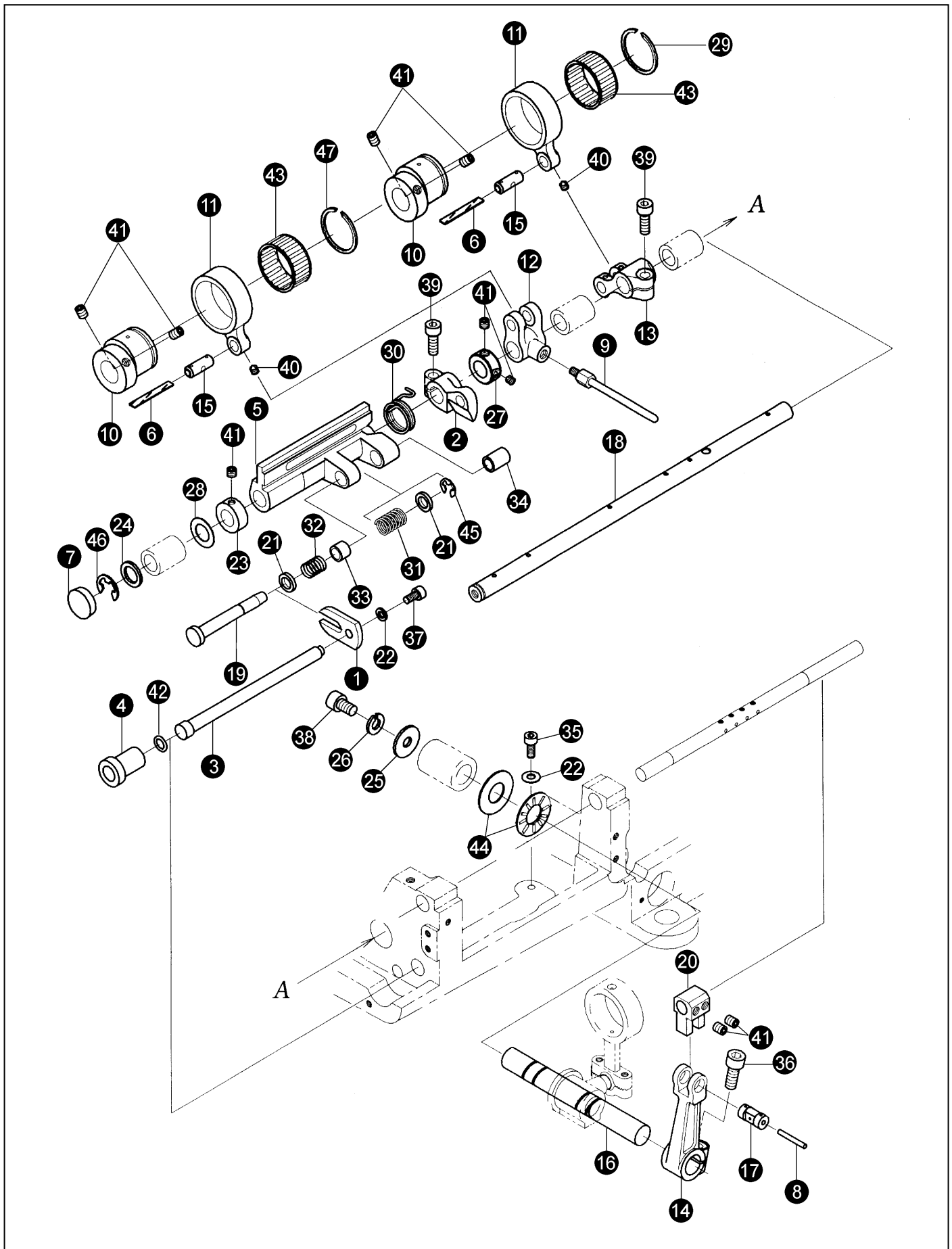



## 8. LOOPER MECHANISM

No.	Ref. No.	Description	Qt.
1	197400009	Looper rocker guide plate	1
2	197400007	Looper rocker stopper	1
3	197400010	Shaft	1
4	197400011	Stud	1
5	197480001	Looper rocker	1
6		Wick	2
7	197400012	Rubber plug	1
8		Wick	1
9	197490001	Tack - up lever	1
10	197490002	Eccentric	2
11	197490003	Link	2
12	197490005	Take - up drive lever	1
13	1974a0001	Looper drive lever	1
14	197400015	Lever	1
15	008400017	Pin	2
16	197400013	Shaft	1
17	197400016	Pin	1
18	197400018	Looper shaft	1
19	197480002	Set shaft	1
20	197400017	Retainer bar holder	1
21	197480003	Washer	2
22	008230003	Washer 4	2
23	197400019	Collar	1
24	197400022	Washer	1
25	197400014	Washer	1
26	S150603003	Washer 6	1
27	197400020	Collar	1
28	197400021	Washer	1
29	197490004	C - type ring	2
30	197400008	Spring	1
31	197480004	Spring	1
32	197480005	Spring	1
33	197480006	Bushing	1
34	197480007	Bushing	1
35	S150209044	Screw M4 x 8	1
36	S150299024	Screw M6 x 14	1
37	S150209044	Screw M4 x 8	2
38	S150299024	Screw M6 x 14	1
39	S150299002	Screw M5 x 14	2
40	S150299027	Screw M4 x 4	1
41	S150299028	Screw M5 x 5	7
42	197400025	O - type ring 6 x 1	1
43	S150801040	Needle bearing K25 x 29 x 13	2
44	S150801031	Bearing 81101 (AXK12 x 26 x 8)	1
45	S150620002	E - type ring 5	1
46	S150620009	E - type ring 8	1

# 9 . PRESSER FOOT MECHANISM

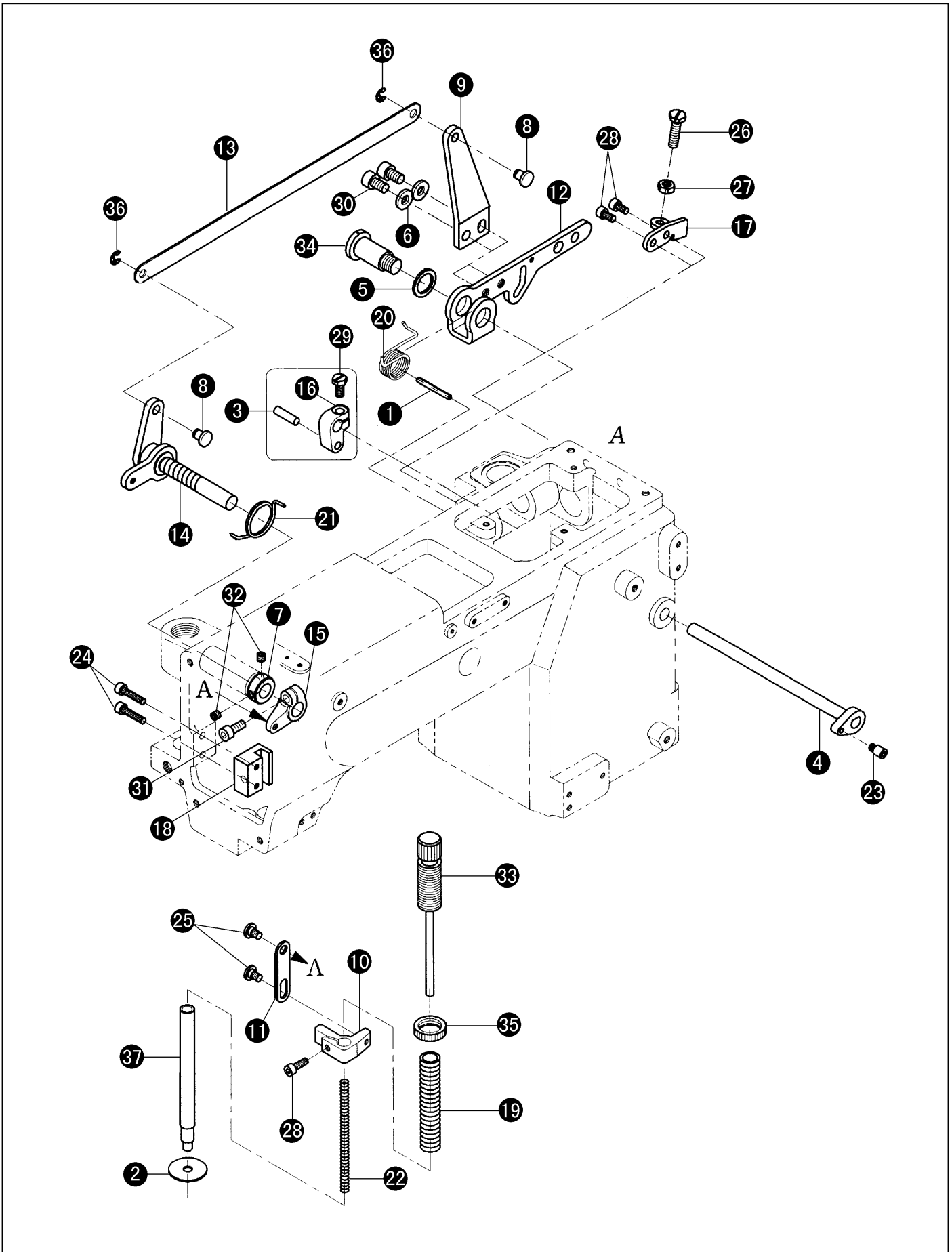

## 9 . PRESSER FOOT MECHANISM

No.	Ref. No.	Description	Qt.
1	S150405030	Pin 3 x 28	1
2	043600005	Oil fence	1
3	008600018	Pin	1
4	197620002	Shaft	1
5	197600003	Washer	1
6	008310001	Washer 6	2
7	110400006	Collar	1
8	197630002	Pin	2
9	197630001	Lever	1
10	197640001	Presser bar slide block	1
11	197640002	Plate	1
12	197600001	Presser bar lever	1
13	197630003	Lever	1
14	197631000	Crank assy.	1
15	197640003	Crank, front	1
16	197610001	Crank, rear	1
17	197600006	Stopper	1
18	197600008	Slide block guide	1
19	197600011	Spring	1
20	197600004	Spring	1
21	197600005	Spring	1
22	197600010	Spring	1
23	197620001	Shaft	1
24	S150299026	Screw M4 x 16	2
25	197630005	Screw	2
26	197730005	Screw	1
27	197730008	Nut	1
28	S150299005	Screw M4 x 10	3
29	S150204002	Screw M5 x 10	1
30	S150299006	Screw M6 x 10	2
31	S150299003	Screw M5 x 10	1
32	S150299027	Screw M4 x 4	2
33	197650001	Screw	1
34	197600002	Shaft	1
35	110610002	Nut	1
36	S150620004	E - type ring 4	2
37	197600009	Presser bar	1

# 10. LUBRICATION MECHANISM

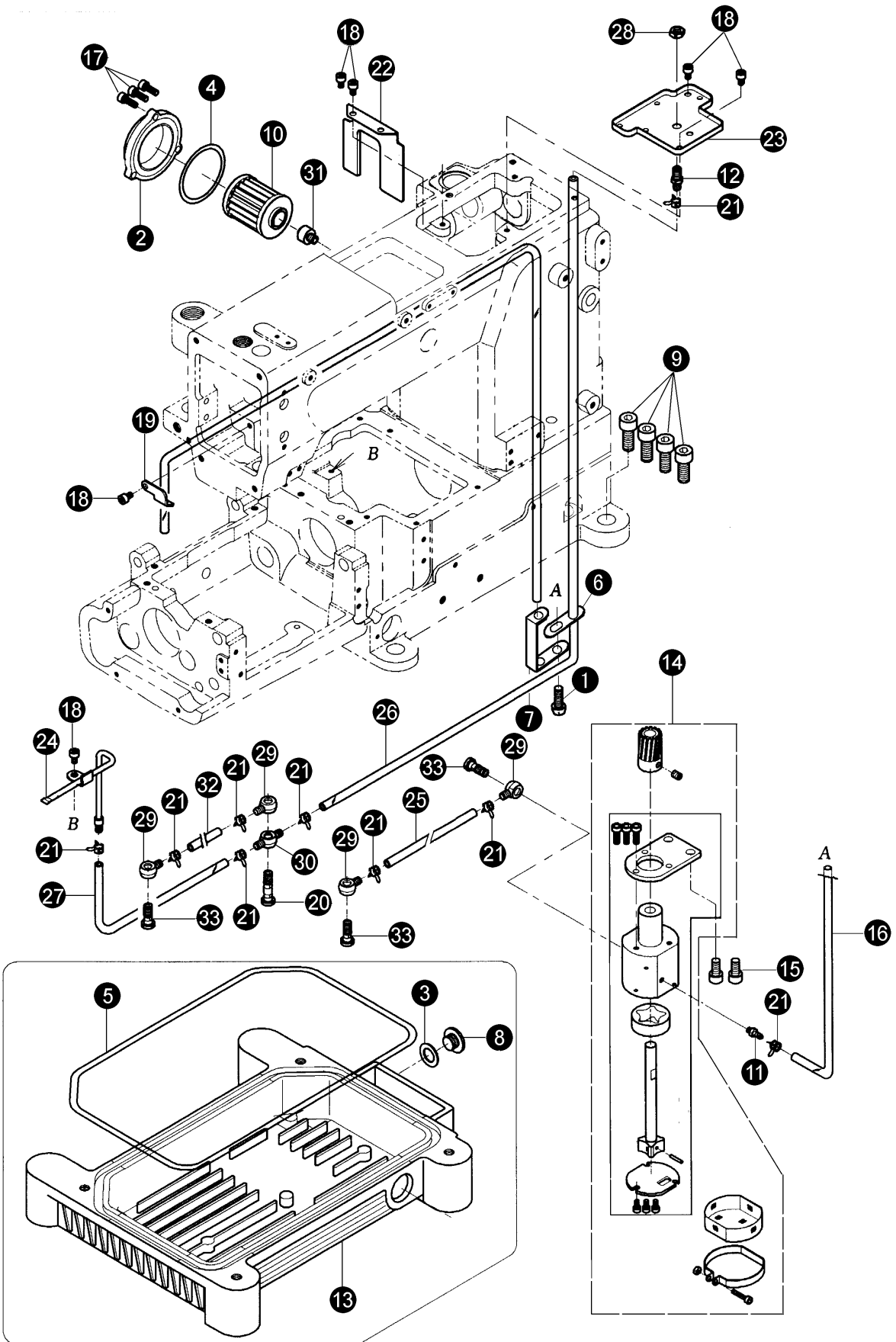

## 10. LUBRICATION MECHANISM

No.	Ref. No.	Description	Qt.
1	S150202010	Screw M4 x 6	1
2	028700023 - - W	Oil filter cover	1
3	110310004	Seal ring	1
4	S150650003	O - type ring GB1235 - 85	1
5	197900002	Seal ring	1
6	110300014	Oil tube clamp	1
7	116300015	Oil tube clamp	1
8	028700026	Screw	1
9	S150209103	Screw M8 x 16	4
10	028770001	Oil filter assy	1
11	197900009	Nozzle	1
12	197900004	Nozzle	1
13	197900001	Oil reservoir	1
14	197910000	Oil pump assy	1
15	S150299024	Screw M6 x 14	2
16	197900005	Oil tube	1
17	S150299032	Screw M4 x 14	3
18	S150202009	Screw M4 x 5	6
19	197900006	Tube holder	1
20	197900007	Screw	1
21	110300012	Oil tube clamp	8
22	197900015	Oil fence	1
23	197900003	Oil releaser	1
24	197920000	Oil tube	1
25	197900005	Oil tube	1
26	197900005	Oil tube	1
27	197900005	Oil tube	1
28	S150503005	Nut M6	1
29	028700010	Joint	4
30	110340001	Joint	1
31	028700022	Screw	1
32	197900005	Oil tube	1
33	197900008	Screw	3

# 11. REAR PULLEY MECHANISM (1)

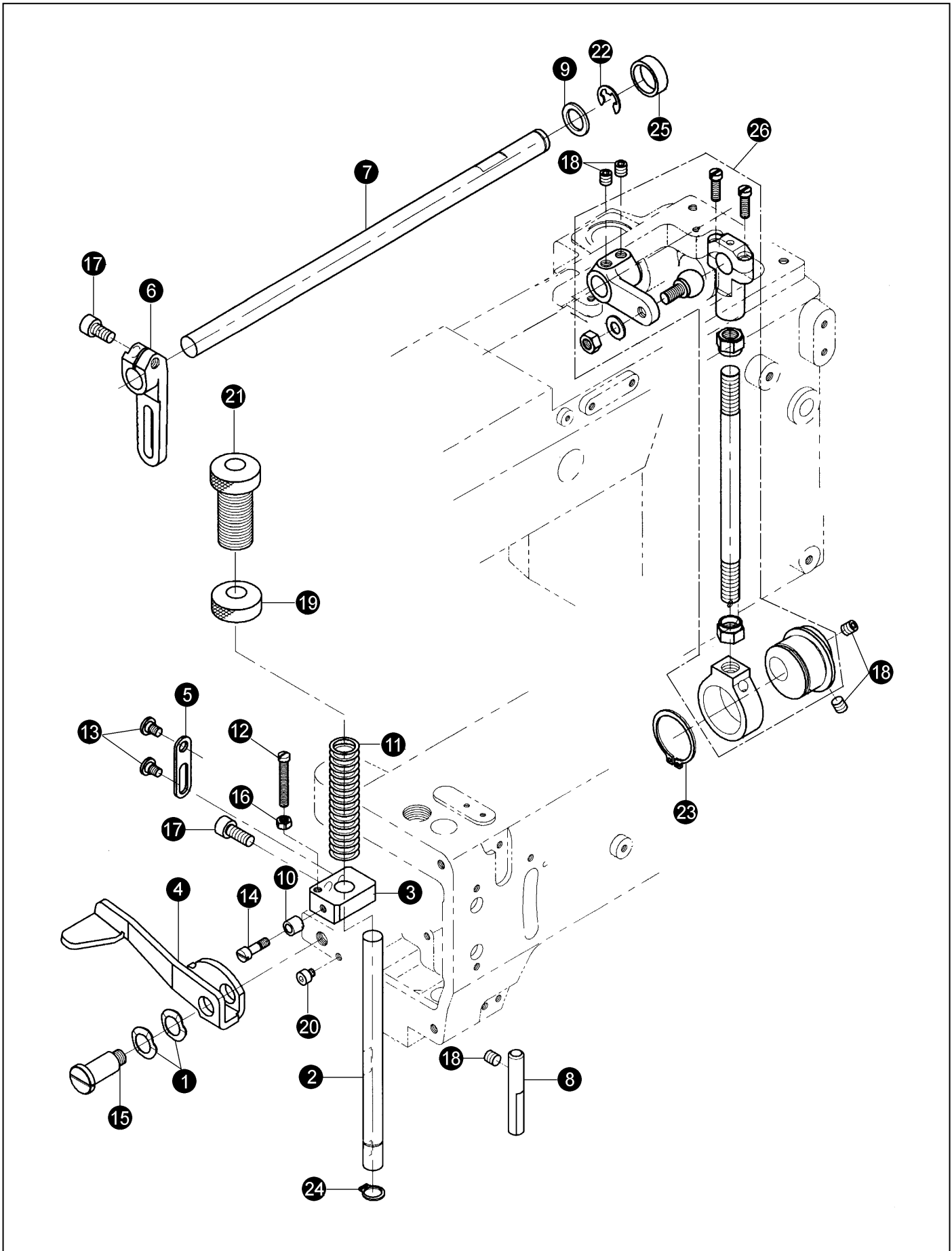

## 11. REAR PULLEY MECHANISM (1)

No.	Ref. No.	Description	Qt.
1	197150002	Washer 12	2
2	197700001	Presser bar	1
3	197710001	Lifter block	1
4	197700004	Lever	1
5	197630004	Lifter plate	1
6	197730001	Crank, left	1
7	197700011	Shaft	1
8	197700006	Stopper	1
9	197700012	Washer	1
10	197710002	Roll pole	1
11	197700003	Spring	1
12	197710004	Screw SM11/64" x 40 x 30	1
13	197630005	Screw	2
14	197710003	Screw	1
15	197700005	Pin	1
16	028100035	Nut SM11/64"(4.37) x 40	1
17	S150299024	Screw M6 x 14	2
18	S150299029	Screw M6 x 6	5
19	197700013	Nut	1
20	S150299026	Screw M4 x 16	1
21	197700002	Nut	1
22	S150620003	E - type ring 9	1
23	S150617019	Collar 28	1
24	S150617017	E - type ring 10	1
25	197100013	Rubber plug	1
26	197740000	Right crank assy	1

## 12. REAR PULLY MECHANISM (2)

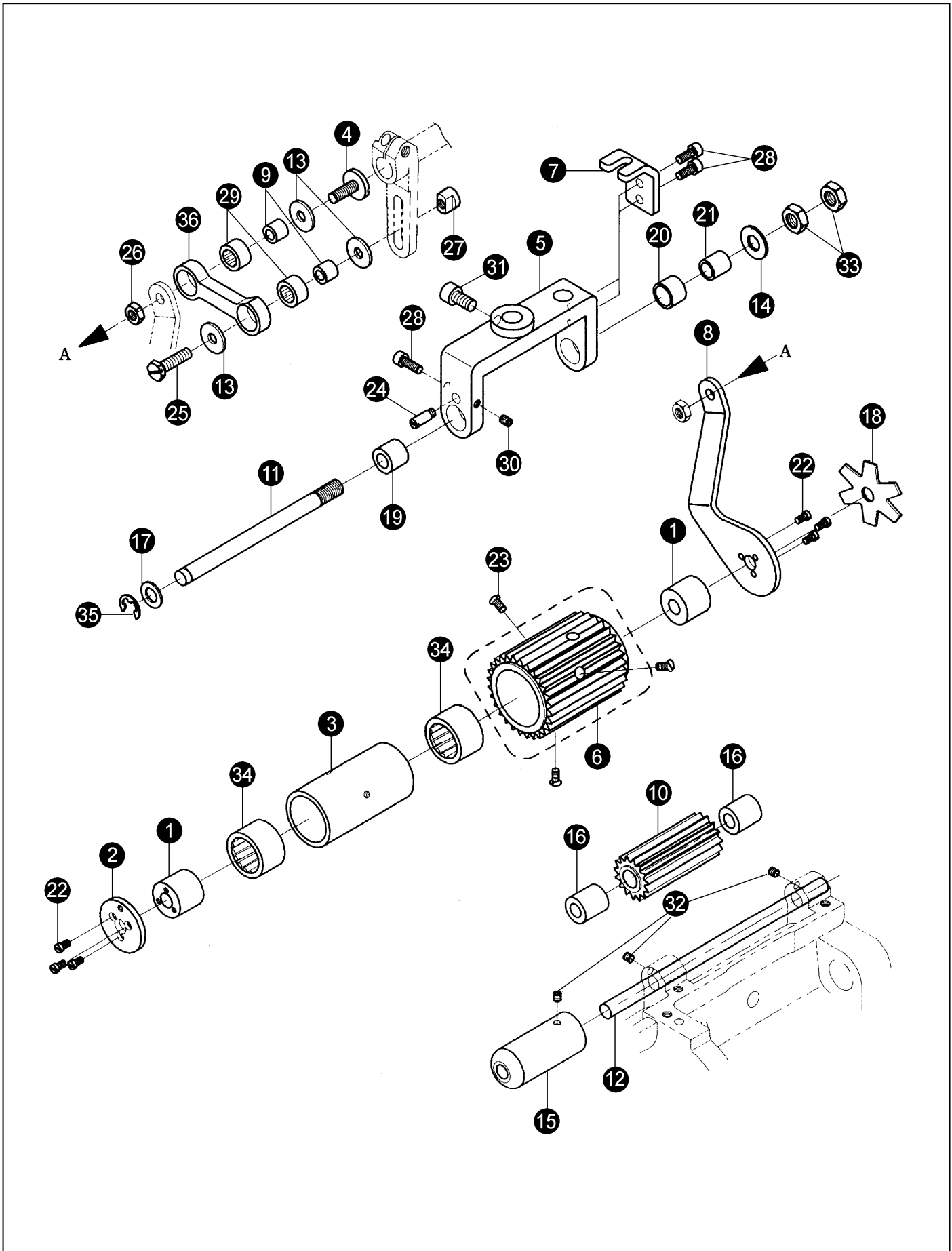



## 12. REAR PULLEY MECHANISM (2)

No.	Ref. No.	Description	Qt.
1	197720006	Sleeve	2
2	197720012	Stopper	1
3	197720005	Sleeve	1
4	197730007	Screw	1
5	197720001	Rear pulley Holder	1
6	197720003	Rear pulley	1
7	197720014	Stopper	1
8	197720011	Connecting plate	1
9	197730003	Bearing sleeve	2
10	197700007	Rear pulley gear	1
11	197720002	Shaft	1
12	197700009	Shaft	1
13	197730004	Washer	3
14	197720015	Washer	1
15	197700010	Guide collar	1
16	197700008	Sleeve	2
17	110E10003	Washer	1
18	197720010	Pulley plate spring	1
19	197720007	Bushing	1
20	197720008	Bushing	1
21	197720009	Bushing	1
22	197720016	Screw SM1/8"(3.18) x 44 x 6	6
23	197720004	Screw	3
24	197720013	Pin	1
25	197730005	Screw	1
26	197730008	Nut SM7/32"(5.56) x 32	1
27	197730006	Slide block	1
28	S150299001	Screw M4 x 12	3
29	S150801099	Needle bearing K9.65 x 14.3 x 8	2
30	S150299027	Screw M4 x 4	1
31	S150299006	Screw M6 x 10	1
32	S150299027	Screw M4 x 4	3
33	S150504007	Nut M8	2
34	S150899023	Bearing HFL2026	2
35	S150620005	E - type ring 6	1
36	197730002	Lever	1

# 13. GAUGE PARTS

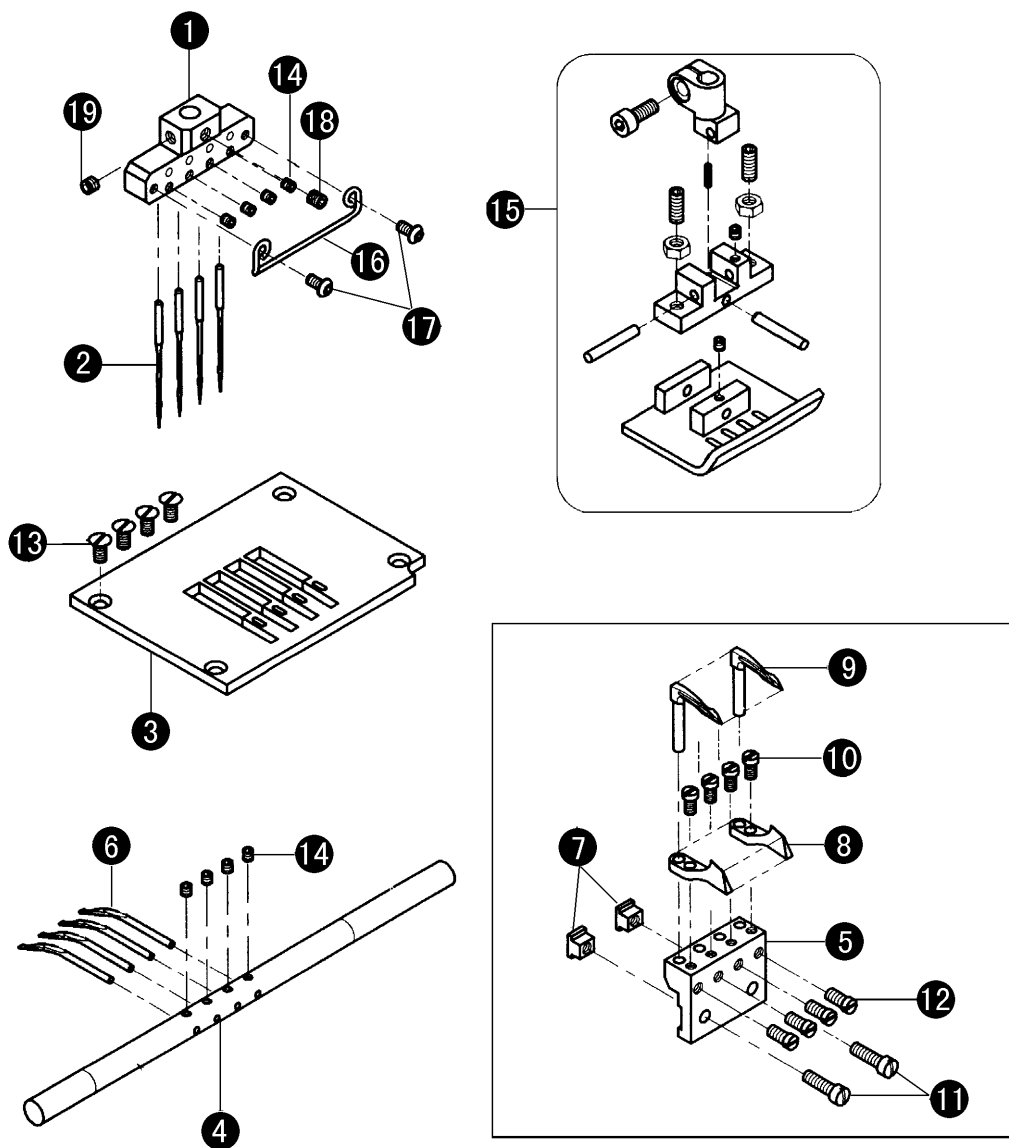

### 13. GAUGE PARTS

No.	Ref. No.	Description	Qt.
1	197320002	Needle clamp	1
2	S150901009	Needle DV x 57 14	4
3	197100024	Throat plate	1
4	197400024	Retainer holder	1
5	197480009	Looper holder	1
6	197400026	Retainer looper	4
7	197480008	Bracket	2
8	197480010	Needle guard	4
9	197480011	Looper	4
10	197480014	Screw SM1/8"(3.18) x 44 x 6	4
11	197480013	Screw SM9/64"(3.57) x 40 x 11.5	2
12	197480012	Screw SM9/64"(3.57) x 40 x 7	4
13	110400023	Screw	4
14	S150299008	Screw M3 x 3 GB80 - 85	8
15	197660000	Presser foot assy	1
16	197320001	Thread guide	1
17	S150299030	Screw M3 x 6	2
18	S150299017	Screw M4 x 4	1
19	S150299027	Screw M4 x 4	1

# 14. GUIDE ROLLER MECHANISM

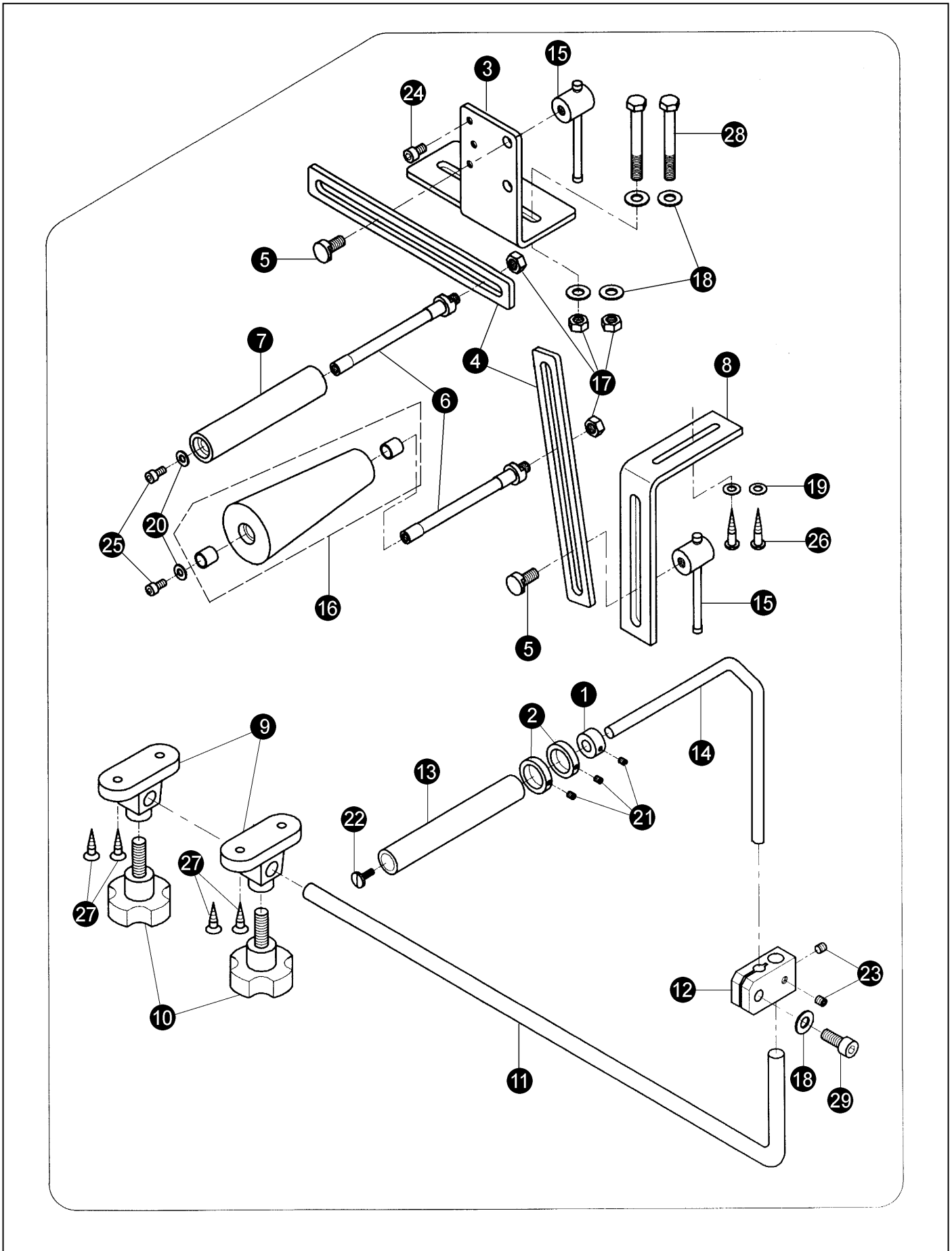

## 14. GUIDE ROLLER MECHANISM

No.	Ref. No.	Description	Qt.
1	197F01303	Collar	1
2	197F01302	Collar	2
3	197F01006	Rear roller bracket	1
4	197F01103	Slide plate	2
5	197F01009	Screw	2
6	197F01102	Shaft	2
7	197F01101	Rear guide roller	1
8	197F01007	Bracket	1
9	197F01401	Bracket	2
10	197F01402	Knob	2
11	197F01008	Support pole	1
12	197F01010	Connecting	1
13	197F01301	Roller	1
14	197F01304	Shaft	1
15	197F01500	Handle assy	2
16	197F01210	Under guide roller assy	1
17	S150503007	Nut GB70 - 85 M8 x 20	4
18	S150607013	Washer 8	5
19	S150610007	Washer 6	2
20	S150607009	Washer 5	2
21	S150299027	Screw GB77 - 85 M4 x 4	3
22	110150007	Screw	1
23	S150299010	Screw M6 x 8	2
24	S150299006	Screw M6 x 10	1
25	S150299004	Screw M5 x 12	2
26	S150221002	Wood screw GB845 - 76 5 x 12	2
27	S150224006	Wood screw GB100 - 85 6.2 x 32	4
28	S150108014	Screw M8 x 65	2
29	S150209060	Screw M8 x 20	1

# 15. THREAD STAND AND TABLE

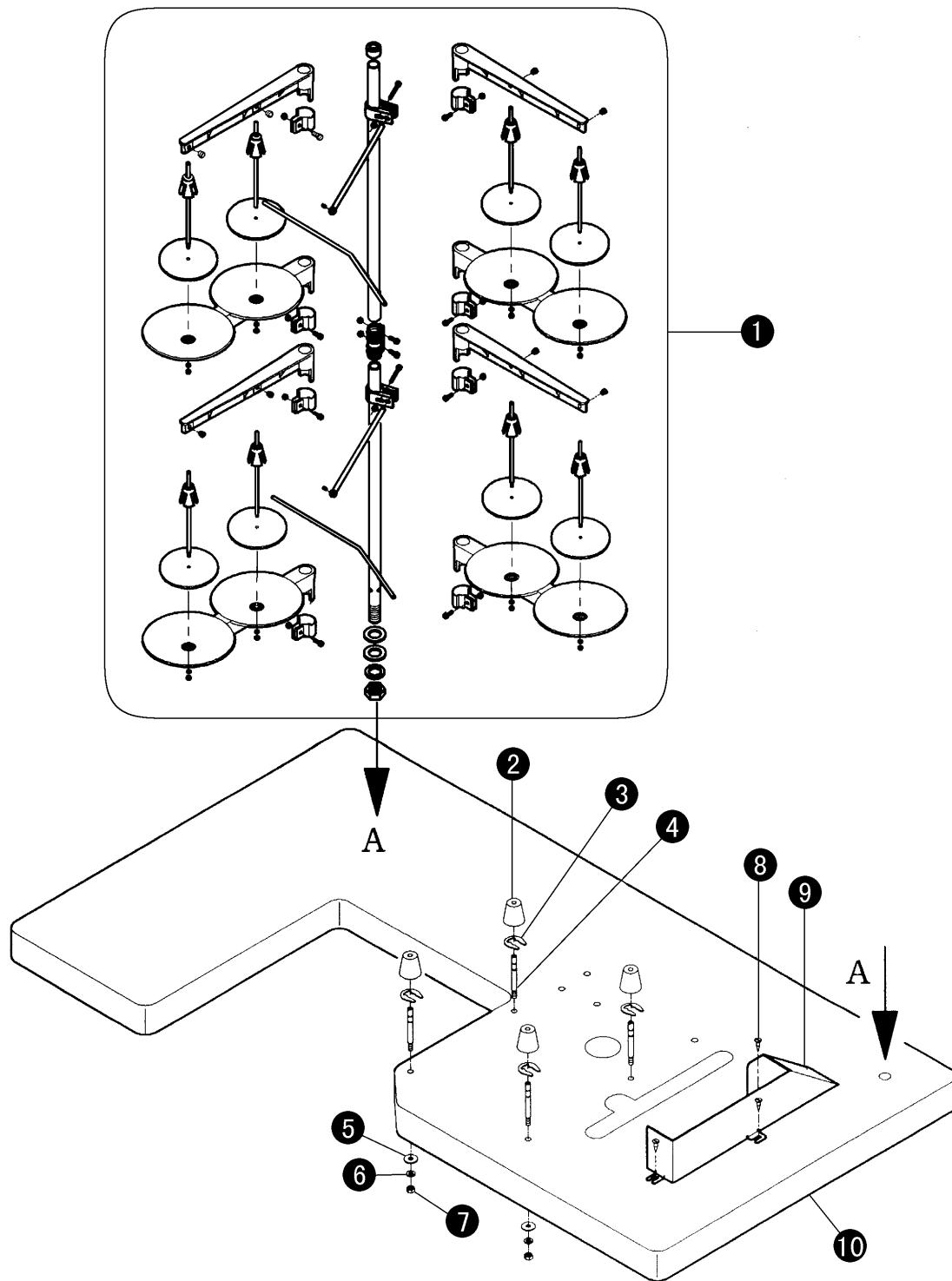

## 15. THREAD STAND AND TABLE

No.	Ref. No.	Description	Qt.
1	197X00000	GXJ - 8 Thread stand assy	1
2	110F01002	Cushion rubber	4
3	S150620005	E - type ring 6	4
4	197F01003	Bolt	4
5	S150610007	Washer 6	4
6	S150601004	Washer GB93 - 76 6	4
7	S150503005	Nut 6	4
8	W050101015	Wood screw 5 x 18	3
9	197F01002	Lower Belt cover	1
10	197F01005	Table	1

## 321 - 12/- 9W assembly diagram of main thread guide assy

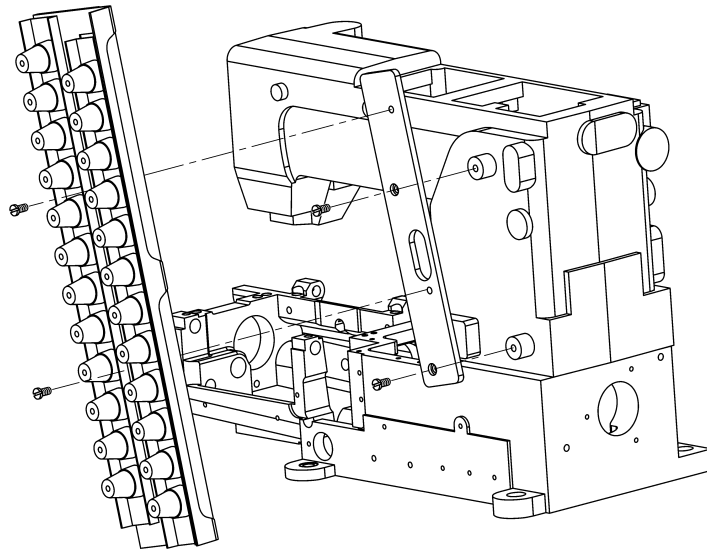

## 321 series of instructions to adjust the length of needle

321 series of adjustments of the length of needles used during the 321 series, there will be two common sizes of needle, the differences between them are: the length of the difference of 2mm. So, for the convenience of customers, will be attached to a length of needles to adjust pads to adjust to customers on their own needle exchange. As follows

First, the factory is set to: the early positioning in the assembly (standard SCHMETZ Needle DVX57, 14 #), the use of 3mm -thick pads to adjust the length of needle positioning the needle bar connector (197310004) and the needle bar and slider (197300002) of the distance between, as shown

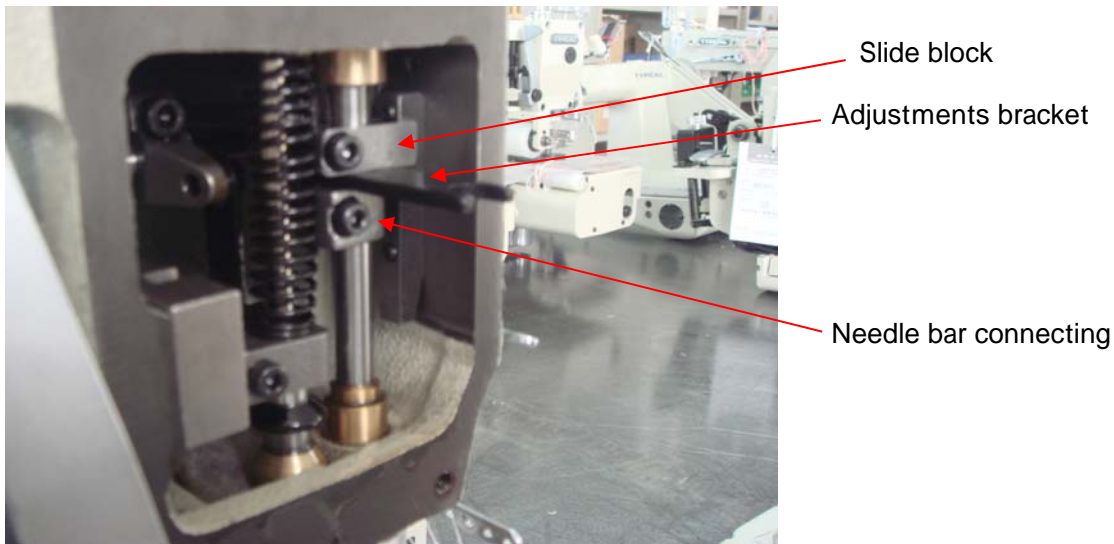

Second, the customers changed to a shorter course, with a larger needle (recommended SCHMETZ Needle UY113 GS, 16 #), change is: Loosen the needle bar connector screw, the needle bar down, with 1mm thick pads to adjust the length of needle positioning the needle bar connector (197310004) and the needle bar and slider (197300002) the distance between the can.

Note: You can not use more than 16 # machine needle, if the need to install more than 16 needle, please adjust the machine or replace other models.



Special - use parts for 321 - 12 / 321 - 9W

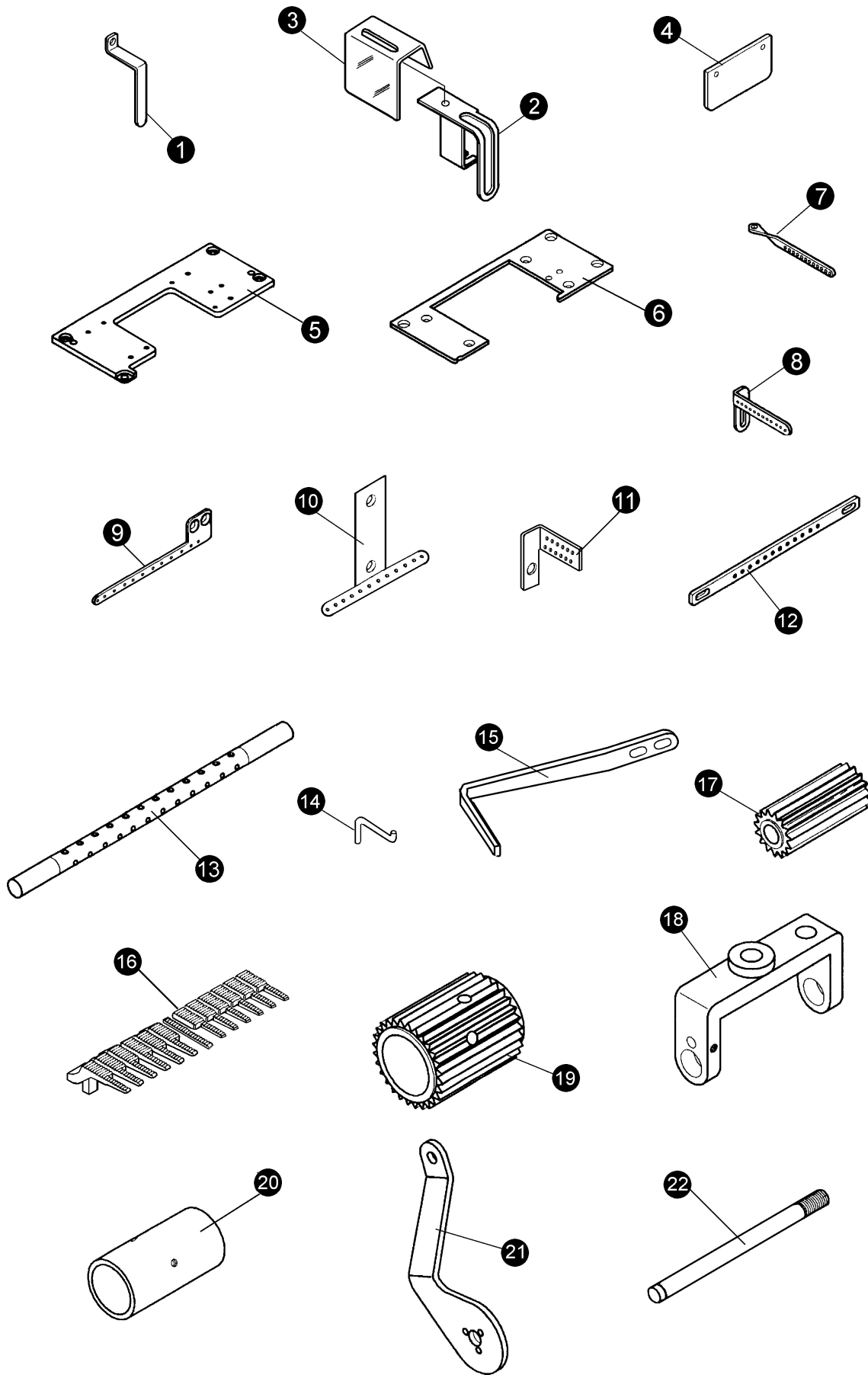

Special - use parts for 321 - 12 / 321 - 9W

No.	Ref.No.	Description	Qt.	
			321 - 12	321 - 9W
1	197C00001	Thread take - up lever guard	1	1
2	197C10001	Needle bar guard	1	1
3	197C10002	Needle bar cover	1	1
4	197C00002	Eye guard	1	1
5	197C00003	Needle plate support bracket	1	
	197100009	Needle plate support bracket		1
6	197C00004	Cover	1	
	197100011	Cover		1
7	197C00005	Thread eyelet	1	1
8	197C00006	Thread eyelet	1	1
9	197C00007	Thread eyelet	1	1
10	197C00008	Thread eyelet	1	1
11	197C00010	Thread eyelet	2	2
12	197C00011	Thread eyelet	1	1
13	197C00013	Thread take - up lever	1	
	197K00002	Thread take - up lever (1/8")		1
14	197C00015	Thread take - up clasper	1	1
15	197C00009	Thread take - up lever	1	1
16	197C00012	Feed dog	1	
	197K00004	Feed dog		1
17	197C00014	Rear pulley gear	1	1
18	197C50001	Rear pulley bracket	1	1
19	197C50002	Rear pulley	1	1
20	197C50003	Rear pulley bushing	1	1
21	197C50004	Connecting plate	1	1
22	197C50005	Rear pulley Shaft	1	1

Special - use parts for 321 - 12 / 321 - 9W

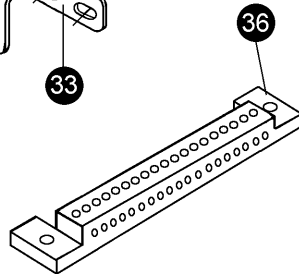
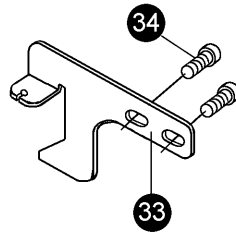
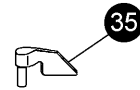
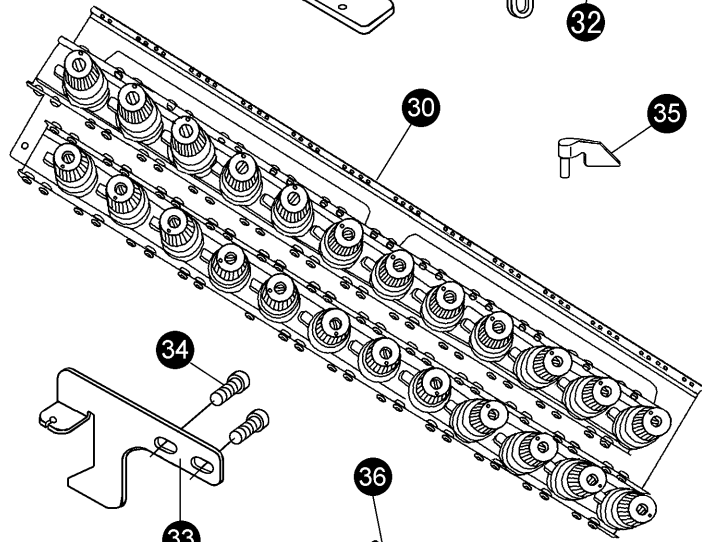
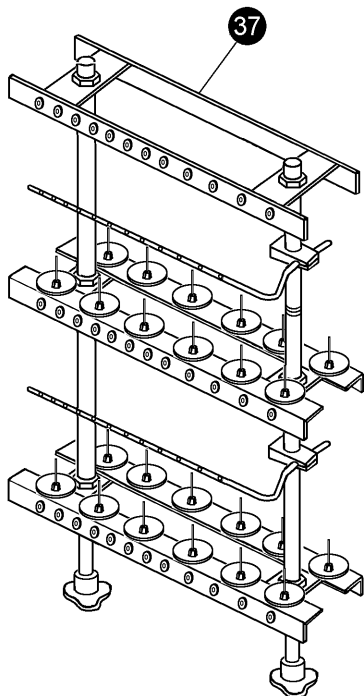
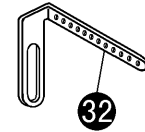
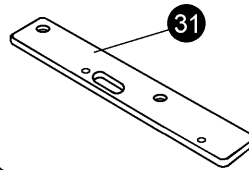
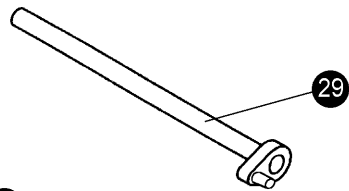
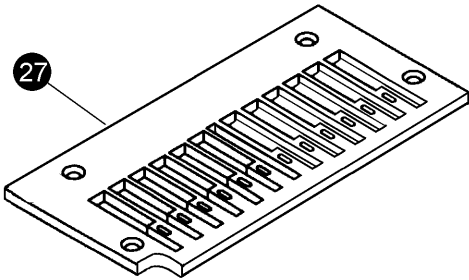
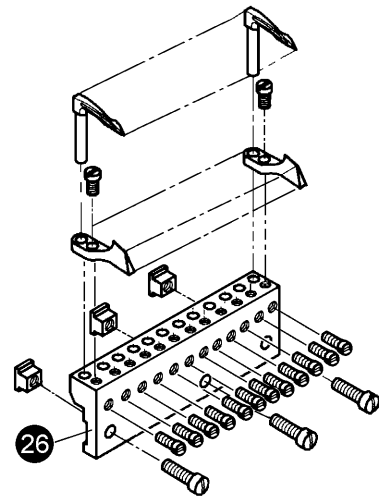
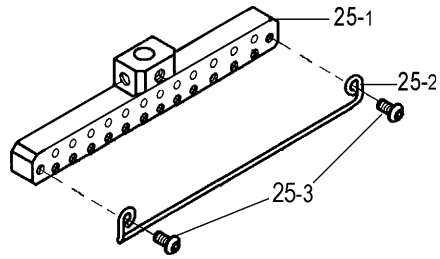
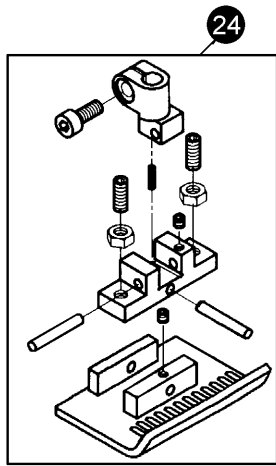

Special - use parts for 321 - 12 / 321 - 9W

No.	Ref.No.	Description	Qt.	
			GK321 - 12	GK321 - 9W
24	197C20000	Presser foot assy	1	
	197K20000	Presser foot assy		1
25 - 1	197C40001	Needle clamp	1	
	197K10002	Needle clamp		1
25 - 2	197C40002	Thread guide	1	1
25 - 3	S150299030	Screw M3 x 6	2	2
26	197C30001	Looper holder	1	
	197K30001	Looper holder		1
27	197C00016	Needle plate	1	
	197K00005	Needle plate		1
28	197K30002	Looper		9
	197480011	Looper	12	
29	197C61000	Thread release front crank assy	1	1
30	197C60002	Main thread guide assy	1	1
31	197C60001	Connection plate	1	1
32	197C00019	Thread guide	1	1
33	197C00027	Presser foot positioning plate	1	1
34	S150209055	Screw M6X12	2	2
35	197K30003	Needle guard plate		9
36	197K30004	Needle guard plate bracket		1
37	197CX0000	Thread stand GXJ - 24	1	1

- Besides adjusting stitch, please laypeople don't debug or maintain.
- Parts are subject to changes in design without prior notice.

**XI'AN TYPICAL INDUSTRIES CO.,LTD.**

---

Add: No. 335 Taibai South Road,  
Xi'an, P.R. China-710068  
Tel: +86-29-88279091 88279150  
Fax: +86-29-88279715 88275215  
E-mail: typical@chinatypical.com  
[Http://www.chinatypical.com](http://www.chinatypical.com)  
[Http://www.chinatypical.com](http://www.chinatypical.com)